

REPORT
RESULTS OF
REDI-SCAPES 115 SERIES UNIT
WITH MIRAGRID 3XT GEOGRID
CONNECTION CAPACITY TESTING

submitted to

REDI-SCAPES

CONFIDENTIAL

Distribution:

- 2 copies REDI-SCAPES
05481 US 31 South
Charlevoix, Michigan 49720
USA
- 2 copies Bathurst, Clarabut Geotechnical Testing, Inc.
1167 Clyde Court, Kingston, Ontario
K7P 2E4 CANADA

This report shall not be reproduced except in full, without written approval of Bathurst, Clarabut Geotechnical Testing, Inc.

Introduction

This report gives the results of a connection testing program carried out to evaluate the mechanical/frictional performance of the connection between Redi-Scapes 115 Series[®] (RS-115) modular concrete block units and Miragrid 3XT geogrid.

The test program was initiated in response to a verbal authorization to proceed from Mr. Jack Bergmann of Redi-Scapes. received 17 February 2009.

The tests were carried out at the laboratories of Bathurst, Clarabut Geotechnical Testing, Inc. in Kingston, Ontario, under the supervision of Mr. Peter Clarabut.

Objectives of test program

The facing-geogrid connection between RS-115 concrete block units and Miragrid 3XT geogrid was investigated using a large-scale connection test apparatus.

The principal objective of the testing was to evaluate the mechanical/frictional performance of these connections. A second objective was to make preliminary recommendations for the selection of long-term tensile connection capacities to be used in the design and analysis of geogrid-reinforced soil wall systems that employ RS-115 blocks in combination with Miragrid 3XT geogrid.

Materials

RS-115 block units are hollow core concrete blocks weighing approximately 55 pounds per unit (68 pounds per units when units are core filled with 3/4 inch crushed limestone, weight/unit measured in our laboratory). The nominal dimensions of the block are 11 inches wide (toe to heel) by 6 inches high by 18 inches long. Construction alignment and wall batter is achieved by means of two cast-in-place concrete keys on the top surface of the units. The installation arrangement is illustrated in **Figure 1**. The blocks used in this series of tests were supplied by Redi-Scapes of Charlevoix, Michigan and designated as BIC 09-022 received 28 April 2009.

Miragrid 3XT is a bi-directional grid composed of 100% polyester multifilament yarn with a tensile strength of 3500 lb/ft in the machine direction (based on ASTM D 6637 method of test and reported on the manufacturers' website - www.tencate.com on 27 October 2009). The geogrid specimens used in this series of testing were cut from roll/lot # 032092006/06244-2-4 received at our laboratory on 8 December 2006. The index strength of roll/lot # 032092006/06244-2-4 was 3484 lb/ft (test data supplied by TC Mirafi).

Apparatus and general test procedure

The method of test used in this investigation follows that reported by Bathurst and Simac (1993) and recommended by the NCMA (Simac et al. 1993) and ASTM D 6638. A brief description of the apparatus and test methodology is presented here. The test apparatus used to

perform the tests is illustrated in **Figure 1**. The test apparatus allows tensile loads of up to 35,000 pounds to be applied to the geogrid while it is confined between two block layers. The facing blocks were laterally restrained and surcharged vertically. Strips of geogrid reinforcement 39 inches wide were attached to a roller clamp and the geogrid extended over the facing block. The next course was then placed over the geogrid simulating the technique that would be used in the field. The spaces between blocks were infilled with a 3/4 inch, 100% crushed limestone aggregate and lightly compacted. **Figure 2** illustrates the particle size distribution of the infill used in this test series. Two wire-line LVDT(s) were connected to the geogrid to measure geogrid displacement at the back of the block. Wall heights were simulated by placing one block course over the interface and applying an additional surcharge load using the vertically-oriented hydraulic jack shown in **Figure 1**. A gum rubber mat was placed over the top layer of blocks to ensure a uniform distribution of vertical surcharge pressure. The connection force was applied at a constant rate of displacement (i.e. 0.75 inches/minute) using a computer-controlled hydraulic actuator. The load and displacements measured by the actuator and the LVDT(s) were recorded continuously during the test by a microcomputer/data acquisition system. All blocks used in the tests were visually inspected to confirm that they were free of defects. Each test was continued until there was a sustained loss in connection strength due to longitudinal member failure or geogrid pullout. Following each test, the blocks were removed and the geogrid examined to confirm failure modes. A virgin specimen of geogrid was used for each test.

The only variable in this series of connection tests was the magnitude of surcharge load.

Test program

The surcharge loads used in the test program are given in **Table 1**. Also tabulated are the failure loads observed for each test.

Test results

A summary of tensile loads at peak capacity and after 3/4 inch displacement is given in **Figure 3**.

The peak connection strength between RS-115 units and Miragrid 3XT for walls between 3.2 and 21.1 feet in height ranged between 32 and 54% of the index tensile strength of 3500 lb/ft in the machine direction (based on ASTM D 6637 method of test and reported on the manufacturers' website - www.tencate.com on 27 October 2009).

Two repeat tests were performed and the results in **Figure 3** illustrate that there is some variability in connection capacity between nominal identical tests. This variability is less than $\pm 10\%$ of the mean peak load criterion required by the NCMA (e.g. maximum variability is 5.2%) and is likely the result of small differences in the setting up of the blocks, compaction of the granular infill, and laying out of the geogrid reinforcement. The trends in data for connection capacities at 3/4 inches of displacement and at peak capacities have been plotted using

bi-linear curves. The reduced connection capacity at lower surcharge loads may be due to the combined effect of lower surcharge pressure and more grid slippage.

Test 2 ended in pullout of the geogrid from between the blocks, all other tests in rupture of one or more longitudinal geogrid members. There was evidence of slippage of the geogrid within the concrete block-geogrid interface in all tests. Geogrid straining and slippage caused abrasion of longitudinal members as the geogrid was pulled across the concrete surfaces. The amount of slippage was seen to diminish with an increase in wall height.

Implications to RS-115 design and construction with Miragrid 3XT geogrid

The long-term design connection strength in the field must be less than the peak capacity envelope determined in this test series for the same method and quality of construction. The NCMA Segmental Retaining Wall Design Manual (First Edition, 1993) recommends that the design connection capacity at a given surcharge load for a critical wall structure be the lesser of the peak capacity divided by a minimum factor of safety (not less than 1.5) or the capacity based on a 3/4 inch displacement criterion. The *design* curve in **Figure 4** is controlled by both the 3/4 inch displacement and the peak connection capacity criterion.

The design capacity envelope illustrated in **Figure 4** should be used with caution. The actual design capacity envelope should be lower if the quality of construction in the field is less than that adopted in this controlled laboratory investigation and/or lower quality concrete is used in the manufacture of the blocks. For example, the interface concrete surfaces should be free of debris before placement of geogrid and blocks in order to minimize abrasion to the geogrid and to maximize the frictional resistance that is developed at the concrete block-geogrid interface.

It is very important that production blocks have uniform dimensions so that there is no stepping at the block joints that can lead to non-uniform frictional resistance at the block-geogrid interface, pinching of the geogrid at the block edges and possibly fracture of the concrete units.

Summary of conclusions

A laboratory testing program was carried out to evaluate the mechanical/frictional connection performance of RS-115 modular block facing units in combination with Miragrid 3XT geogrid. The following conclusions can be drawn:

1. The peak connection strength between RS-115 units and Miragrid 3XT geogrid for walls between 3.2 and 21.1 feet in height ranged between 32 and 54% of the index tensile strength of 3500 lb/ft in the machine direction (based on ASTM D 6637 method of test and reported on the manufacturers' website - www.tencate.com on 27 October 2009).
2. The trends in data for connection capacities at 3/4 inches of displacement and at peak capacities have been plotted using bi-linear curves.
3. Care must be taken during the installation of RS-115 units in order to prevent accumulation of soil and rock debris at the concrete block-geogrid interface surfaces. This debris may significantly reduce the capacity of the RS-115 facing unit-geogrid system.

- The design envelope in **Figure 4** is based on an interpretation of test data as recommended in the NCMA Segmental Retaining Wall Design Manual (First Edition, 1993). The choice of design connection strengths may vary from site to site and quality of construction in the field may require lower design values than those taken from **Figure 4**.



P. Clarabut



R. J. Bathurst, Ph.D., P. Eng.

REFERENCES

ASTM D 6638-01. Standard Test Method for Determining Connection Strength between Geosynthetic Reinforcement and Segmental Concrete Units (Modular Concrete Blocks), American Society for Testing and Materials, West Conshohocken, PA 19428-2958 USA.

Bathurst, R.J. and Simac, M.R., 1993. Laboratory Testing of Modular Unit/Geogrid Facing Connections, *ASTM Symposium on Geosynthetic Soil Reinforcement Testing Procedures*, San Antonio, 19 January 1993.

Simac, M.R., Bathurst, R.J., Berg, R.R. and Lothspeich, S.E., 1993. *NCMA Segmental Retaining Wall Design Manual (First Edition)*, National Concrete Masonry Association, 2302 Horse Pen Road, Herndon, VA 22071-3406.

Table 1

Test Program:

RS-115 modular block unit combination - Miragrid 3XT
geogrid connection

Test number	normal load (lb/ft)	approximate wall height (feet)	approximate number of blocks	tensile capacity (lb/ft) at 3/4 inch displacement	peak tensile capacity (lb/ft)
1	990	9.6	19.1	1053	1658
2	336	3.2	6.5	691	1108
3	653	6.3	12.6	976	1438
4	983	9.5	19.0	1014	1823
5	1313	12.7	25.4	1191	1748
6	1643	15.9	31.8	1262	1809
7	990	9.6	19.1	1068	1768
8	2180	21.1	42.1	1438	1906

LEGEND

- | | | | | | |
|---|----------------------------|----|--------------------|----|--|
| 1 | RS-115 block | 6 | guide rail | 11 | platform |
| 2 | Miragrid 3XT | 7 | LVDT clamp | 12 | wire-line LVDT |
| 3 | loading platen | 8 | surcharge actuator | 13 | computer controlled hydraulic actuator |
| 4 | roller clamp | 9 | loading frame | 14 | gum rubber mat |
| 5 | lateral restraining system | 10 | spacers | | |

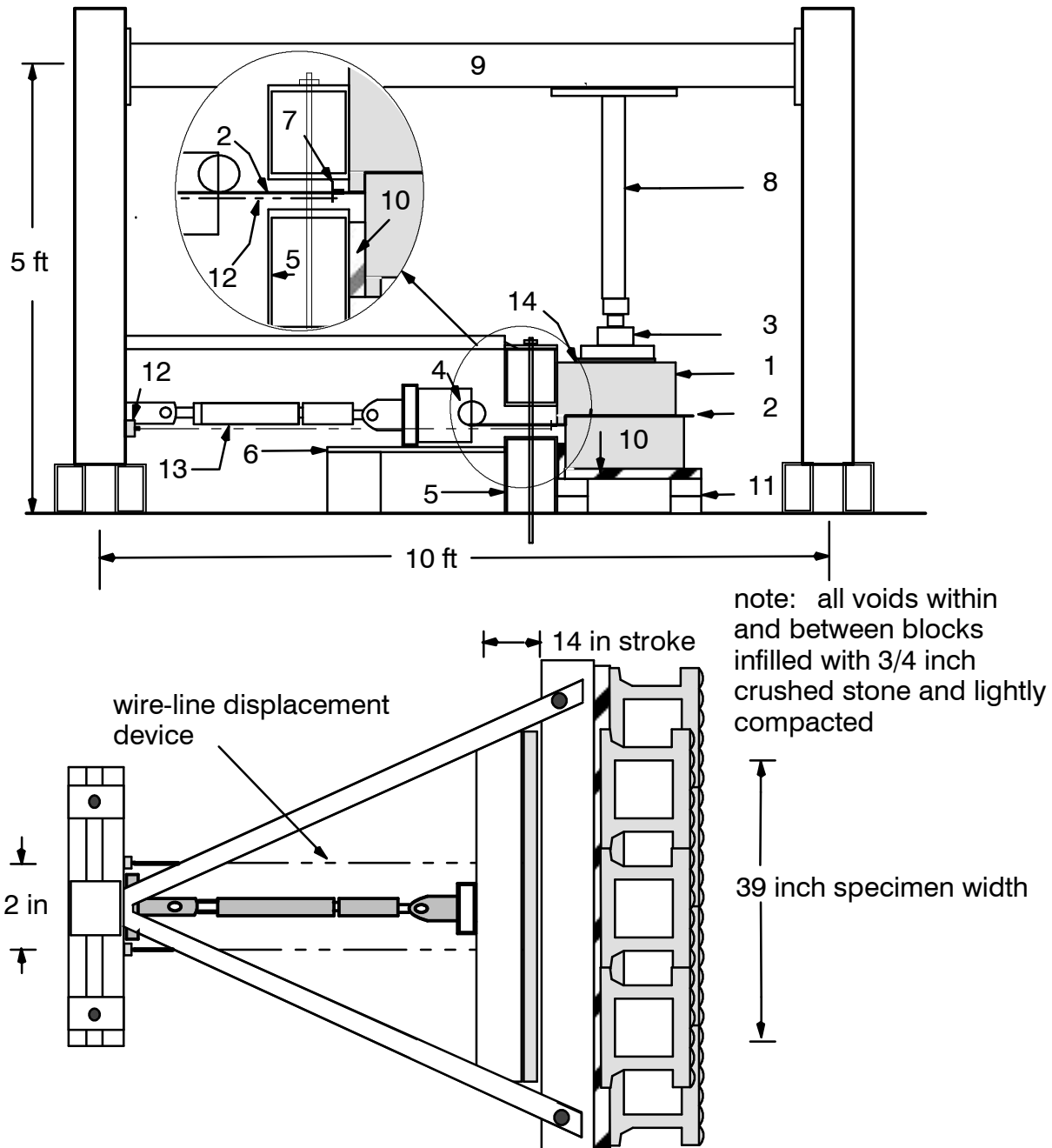

Figure 1: Schematic of connection test apparatus showing RS-115 block units and Miragrid 3XT geogrid

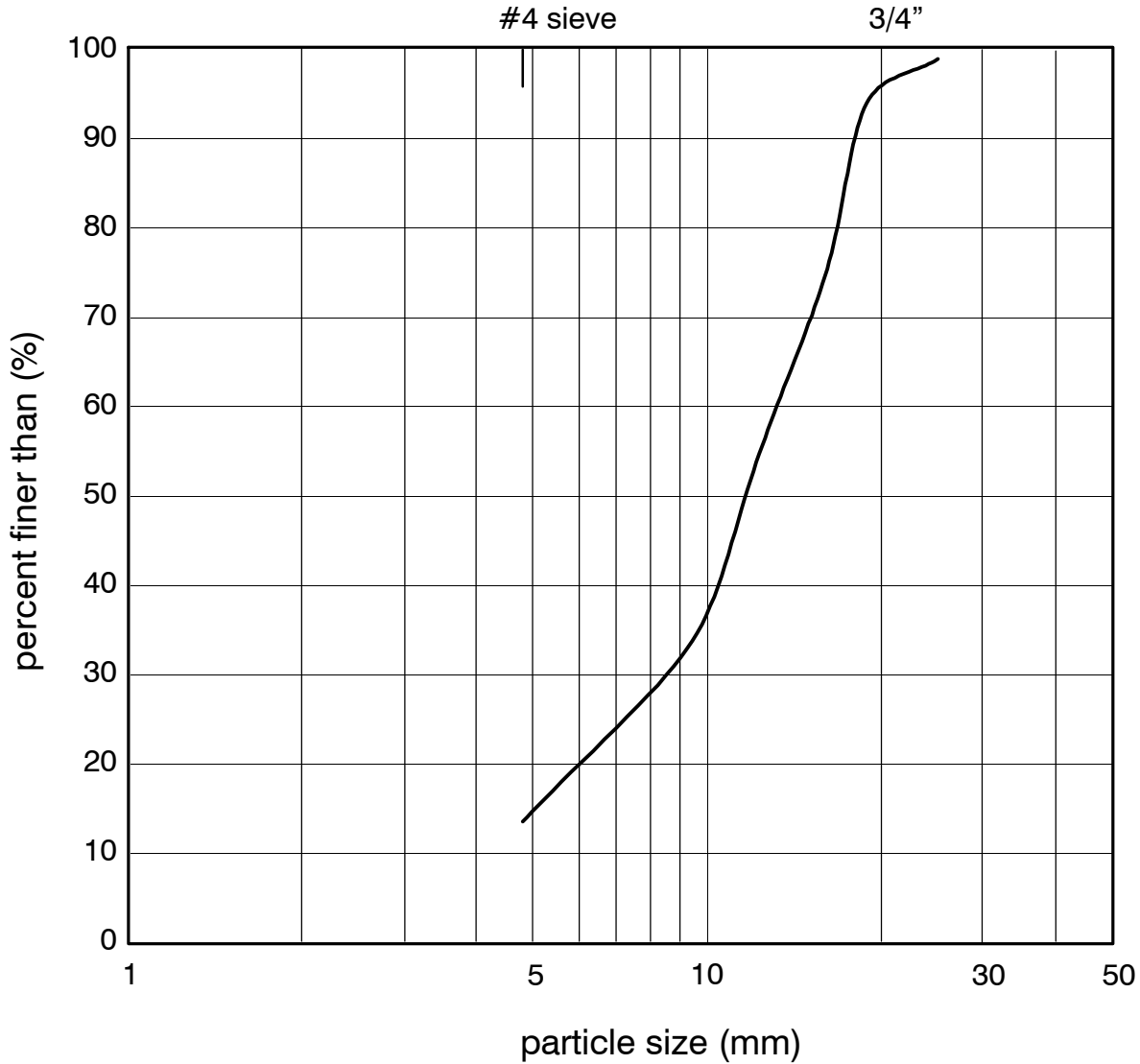

Figure 2: Particle size distribution for 100% crushed granular stone used in RS-115 block tests

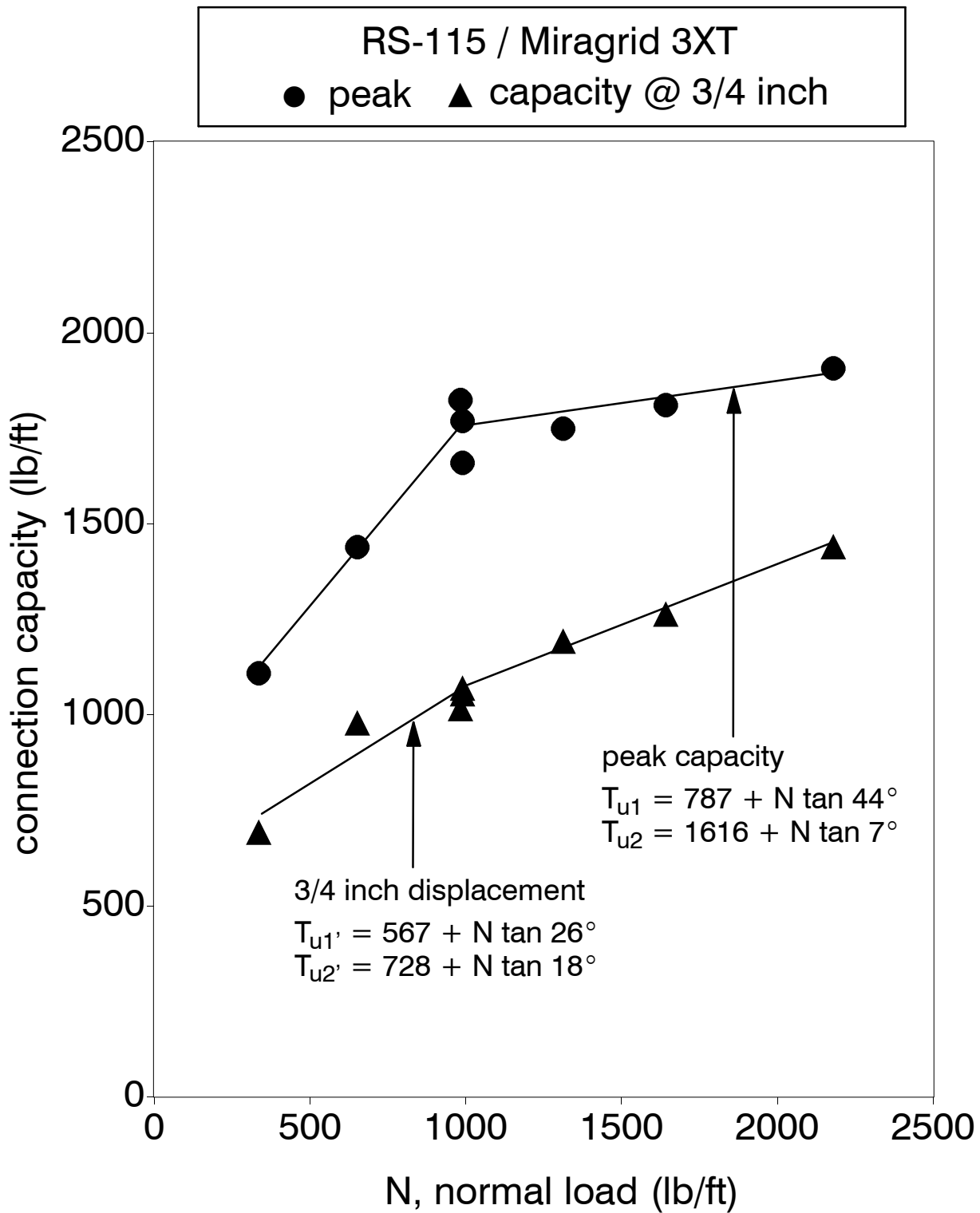

Figure 3: Summary of connection capacities for RS-115 block units and Miragrid 3XT grid

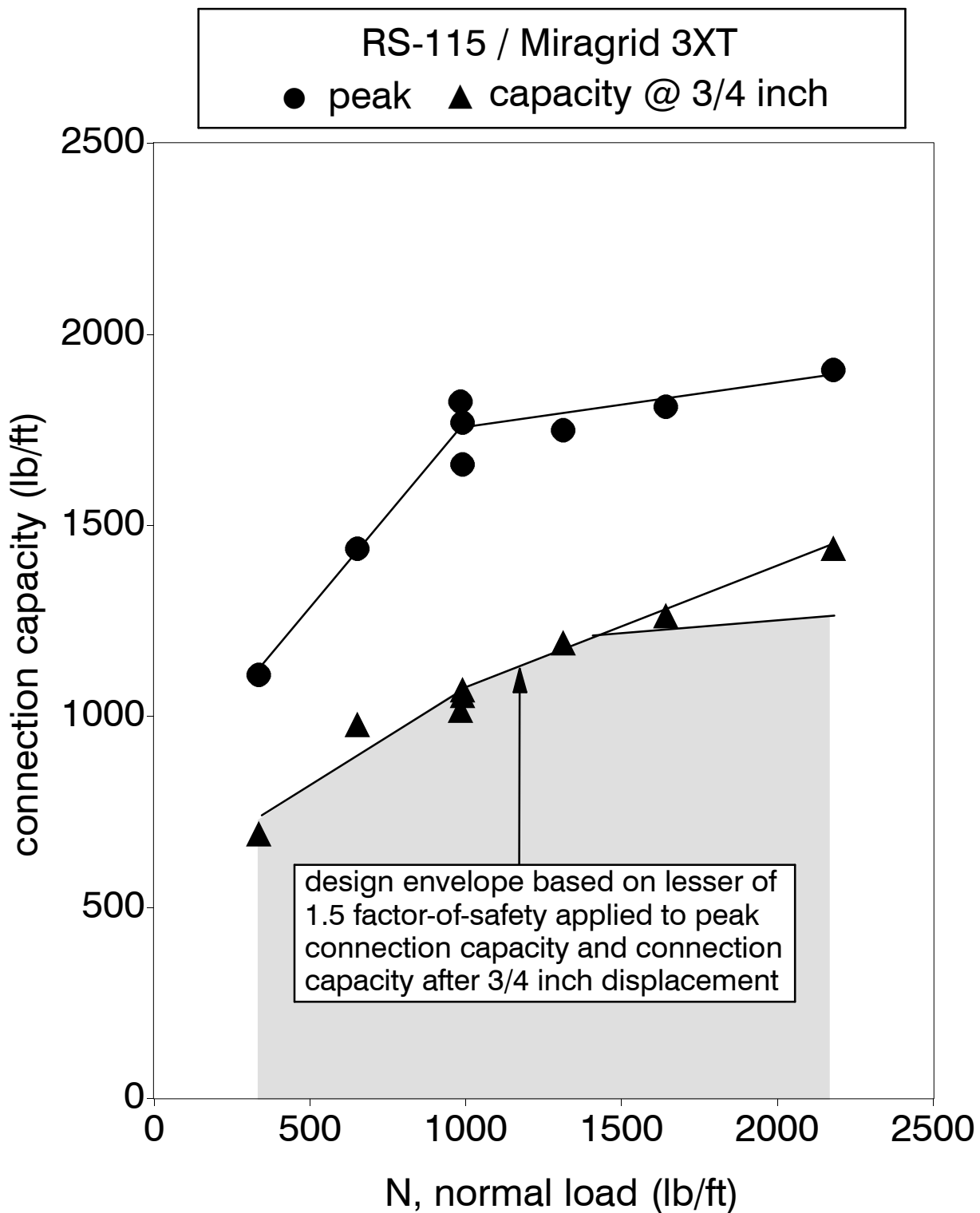

Figure 4: Preliminary design capacity envelope for RS-115 block units / Miragrid 3XT geogrid combination

REPORT
RESULTS OF
REDI-SCAPES 115 SERIES UNIT
WITH MIRAGRID 5XT GEOGRID
CONNECTION CAPACITY TESTING

submitted to

REDI-SCAPES
CONFIDENTIAL

Distribution:

- 2 copies REDI-SCAPES
05481 US 31 South
Charlevoix, Michigan 49720
USA
- 2 copies Bathurst, Clarabut Geotechnical Testing, Inc.
1167 Clyde Court, Kingston, Ontario
K7P 2E4 CANADA

This report shall not be reproduced except in full, without written approval of Bathurst, Clarabut Geotechnical Testing, Inc.

Introduction

This report gives the results of a connection testing program carried out to evaluate the mechanical/frictional performance of the connection between Redi-Scapes 115 Series[®] (RS-115) modular concrete block units and Miragrid 5XT geogrid.

The test program was initiated in response to a verbal authorization to proceed from Mr. Jack Bergmann of Redi-Scapes. received 17 February 2009.

The tests were carried out at the laboratories of Bathurst, Clarabut Geotechnical Testing, Inc. in Kingston, Ontario, under the supervision of Mr. Peter Clarabut.

Objectives of test program

The facing-geogrid connection between RS-115 concrete block units and Miragrid 5XT geogrid was investigated using a large-scale connection test apparatus.

The principal objective of the testing was to evaluate the mechanical/frictional performance of these connections. A second objective was to make preliminary recommendations for the selection of long-term tensile connection capacities to be used in the design and analysis of geogrid-reinforced soil wall systems that employ RS-115 blocks in combination with Miragrid 5XT geogrid.

Materials

RS-115 block units are hollow core concrete blocks weighing approximately 55 pounds per unit (weight/unit measured in our laboratory). The nominal dimensions of the block are 11 inches wide (toe to heel) by 6 inches high by 18 inches long. Construction alignment and wall batter is achieved by means of two cast-in-place concrete keys on the bottom surface of the units. The installation arrangement is illustrated in **Figure 1**. The blocks used in this series of tests were supplied by Redi-Scapes of Charlevoix, Michigan and designated as BIC 09-022 received 28 April 2009.

Miragrid 5XT is a bi-directional grid composed of 100% polyester multifilament yarn with a tensile strength of 4700 lb/ft in the machine direction (based on ASTM D 6637 method of test and reported on the manufacturers' website - www.tencate.com on 27 October 2009). The geogrid specimens used in this series of testing were cut from roll/lot # 031387847/07294-1-3 received at our laboratory on 27 August 2008. The index strength of roll/lot # 031087847/07294-1-3 was 5178 lb/ft (test data supplied by TC Mirafi).

Apparatus and general test procedure

The method of test used in this investigation follows that reported by Bathurst and Simac (1993) and recommended by the NCMA (Simac et al. 1993) and ASTM D 6638. A brief description of the apparatus and test methodology is presented here. The test apparatus used to perform the tests is illustrated in **Figure 1**. The test apparatus allows tensile loads of up to

35,000 pounds to be applied to the geogrid while it is confined between two block layers. The facing blocks were laterally restrained and surcharged vertically. Strips of geogrid reinforcement 39 inches wide were attached to a roller clamp and the geogrid extended over the facing block. The next course was then placed over the geogrid simulating the technique that would be used in the field. The spaces between blocks were infilled with a 3/4 inch, 100% crushed limestone aggregate and lightly compacted. **Figure 2** illustrates the particle size distribution of the infill used in this test series. Two wire-line LVDT(s) were connected to the geogrid to measure geogrid displacement at the back of the block. Wall heights were simulated by placing one block course over the interface and applying an additional surcharge load using the vertically-oriented hydraulic jack shown in **Figure 1**. A gum rubber mat was placed over the top layer of blocks to ensure a uniform distribution of vertical surcharge pressure. The connection force was applied at a constant rate of displacement (i.e. 0.75 inches/minute) using a computer-controlled hydraulic actuator. The load and displacements measured by the actuator and the LVDT(s) were recorded continuously during the test by a microcomputer/data acquisition system. All blocks used in the tests were visually inspected to confirm that they were free of defects. Each test was continued until there was a sustained loss in connection strength due to longitudinal member failure or geogrid pullout. Following each test, the blocks were removed and the geogrid examined to confirm failure modes. A virgin specimen of geogrid was used for each test.

The only variable in this series of connection tests was the magnitude of surcharge load.

Test program

The surcharge loads used in the test program are given in **Table 1**. Also tabulated are the failure loads observed for each test.

Test results

A summary of tensile loads at peak capacity and after 3/4 inch displacement is given in **Figure 3**.

The peak connection strength between RS-115 units and Miragrid 5XT for walls between 3.0 and 30.0 feet in height ranged between 23 and 51% of the index tensile strength of 4700 lb/ft in the machine direction (based on ASTM D 6637 method of test and reported on the manufacturers' website - www.tencate.com on 27 October 2009).

Two repeat tests were performed and the results in **Figure 3** illustrate that there is minor variability in connection capacity between nominal identical tests. This variability is less than $\pm 10\%$ of the mean peak load criterion required by the NCMA (e.g. maximum variability is 2.9%) and is likely the result of small differences in the setting up of the blocks, compaction of the granular infill, and laying out of the geogrid reinforcement. The trend in data for connection capacities at 3/4 inches of displacement has been plotted using a linear curve. The trend in data for peak capacities has been plotted using a bi-linear curve. The reduced connec-

tion capacity at lower surcharge loads may be due to the combined effect of lower surcharge pressure and more grid slippage.

Tests 2 and 3 ended in pullout of the geogrid from between the blocks, all other tests in rupture of one or more longitudinal geogrid members. There was evidence of slippage of the geogrid within the concrete block-geogrid interface in all tests. Geogrid straining and slippage caused abrasion of longitudinal members as the geogrid was pulled across the concrete surfaces. The amount of slippage was seen to diminish with an increase in wall height.

Implications to RS-115 design and construction with Miragrid 5XT geogrid

The long-term design connection strength in the field must be less than the peak capacity envelope determined in this test series for the same method and quality of construction. The NCMA Segmental Retaining Wall Design Manual (First Edition, 1993) recommends that the design connection capacity at a given surcharge load for a critical wall structure be the lesser of the peak capacity divided by a minimum factor of safety (not less than 1.5) or the capacity based on a 3/4 inch displacement criterion. The *design* curve in **Figure 4** is controlled by both the 3/4 inch displacement and the peak connection capacity criterion.

The design capacity envelope illustrated in **Figure 4** should be used with caution. The actual design capacity envelope should be lower if the quality of construction in the field is less than that adopted in this controlled laboratory investigation and/or lower quality concrete is used in the manufacture of the blocks. For example, the interface concrete surfaces should be free of debris before placement of geogrid and blocks in order to minimize abrasion to the geogrid and to maximize the frictional resistance that is developed at the concrete block-geogrid interface.

It is very important that production blocks have uniform dimensions so that there is no stepping at the block joints that can lead to non-uniform frictional resistance at the block-geogrid interface, pinching of the geogrid at the block edges and possibly fracture of the concrete units.

Summary of conclusions

A laboratory testing program was carried out to evaluate the mechanical/frictional connection performance of RS-115 modular block facing units in combination with Miragrid 5XT geogrid. The following conclusions can be drawn:

1. The peak connection strength between RS-115 units and Miragrid 5XT geogrid for walls between 3.0 and 30.0 feet in height ranged between 23 and 51% of the index tensile strength of 4700 lb/ft in the machine direction (based on ASTM D 6637 method of test and reported on the manufacturers' website - www.tencate.com on 27 October 2009).
2. The trend in data for connection capacities at 3/4 inches of displacement has been plotted using a linear curve. The trend in data for peak capacities has been plotted using a bi-linear curve.

3. Care must be taken during the installation of RS-115 units in order to prevent accumulation of soil and rock debris at the concrete block-geogrid interface surfaces. This debris may significantly reduce the capacity of the RS-115 facing unit-geogrid system.
4. The design envelope in **Figure 4** is based on an interpretation of test data as recommended in the NCMA Segmental Retaining Wall Design Manual (First Edition, 1993). The choice of design connection strengths may vary from site to site and quality of construction in the field may require lower design values than those taken from **Figure 4**.



P. Clarabut



R. J. Bathurst, Ph.D., P. Eng.

REFERENCES

ASTM D 6638-01. Standard Test Method for Determining Connection Strength between Geosynthetic Reinforcement and Segmental Concrete Units (Modular Concrete Blocks), American Society for Testing and Materials, West Conshohocken, PA 19428-2958 USA.

Bathurst, R.J. and Simac, M.R., 1993. Laboratory Testing of Modular Unit/Geogrid Facing Connections, *ASTM Symposium on Geosynthetic Soil Reinforcement Testing Procedures*, San Antonio, 19 January 1993.

Simac, M.R., Bathurst, R.J., Berg, R.R. and Lothspeich, S.E., 1993. *NCMA Segmental Retaining Wall Design Manual (First Edition)*, National Concrete Masonry Association, 2302 Horse Pen Road, Herndon, VA 22071-3406.

Table 1

Test Program:

RS-115 modular block unit combination - Miragrid 5XT
geogrid connection

Test number	normal load (lb/ft)	approximate wall height (feet)	approximate number of blocks	tensile capacity (lb/ft) at 3/4 inch displacement	peak tensile capacity (lb/ft)
1	984	9.0	18.1	1253	1933
2	330	3.0	6.1	780	1066
3	661	6.1	12.1	1049	1582
4	984	9.0	18.1	1152	1851
5	1301	11.9	23.9	1355	2147
6	1631	15.0	29.9	1383	2078
7	977	9.0	17.9	1176	1851
8	2188	20.1	40.1	1684	2236
9	3268	30.0	60.0	1899	2374

LEGEND

- | | | | | | |
|---|----------------------------|----|--------------------|----|--|
| 1 | RS-115 block | 6 | guide rail | 11 | platform |
| 2 | Miragrid 5XT | 7 | LVDT clamp | 12 | wire-line LVDT |
| 3 | loading platen | 8 | surcharge actuator | 13 | computer controlled hydraulic actuator |
| 4 | roller clamp | 9 | loading frame | 14 | gum rubber mat |
| 5 | lateral restraining system | 10 | spacers | | |

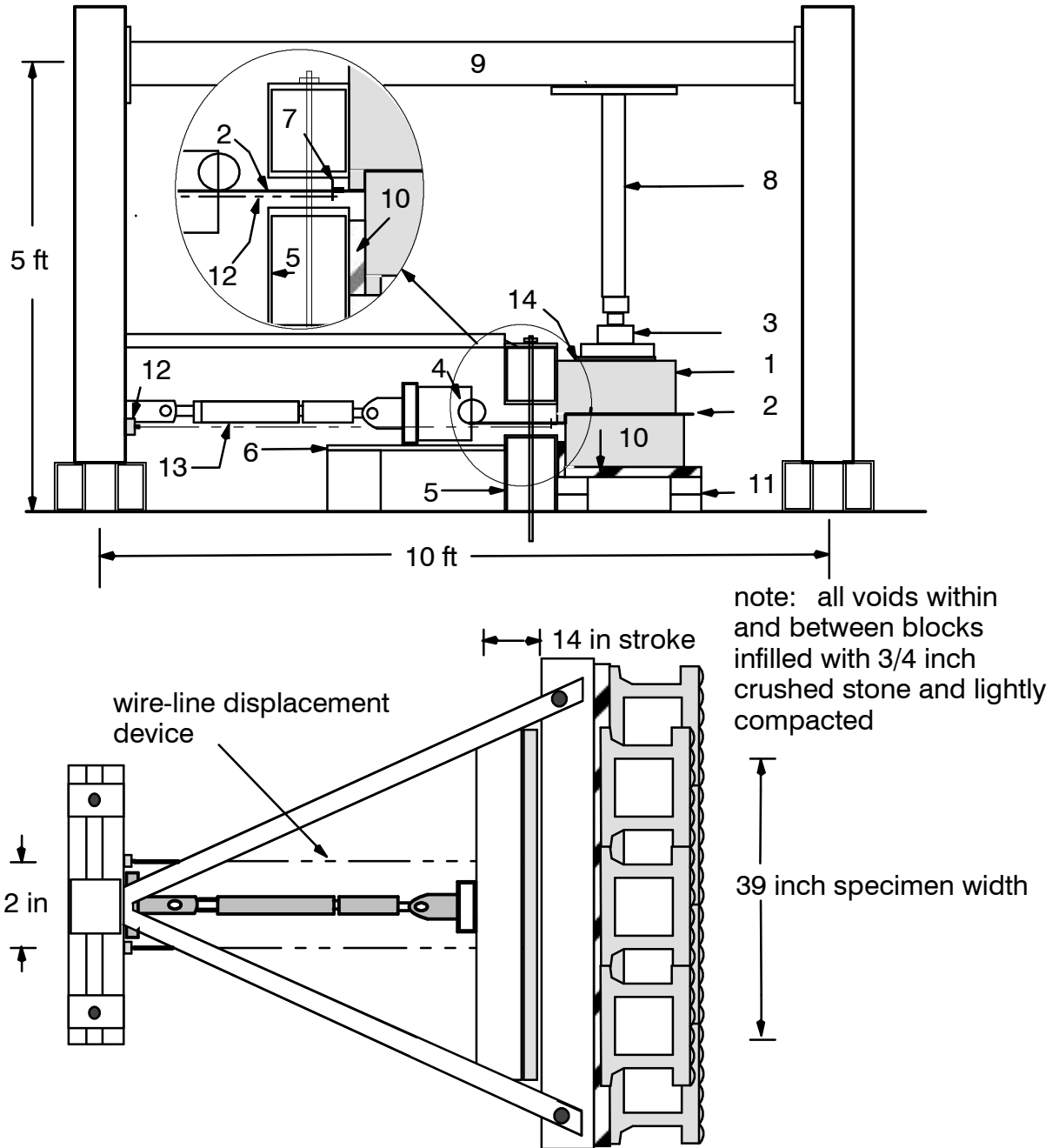

Figure 1: Schematic of connection test apparatus showing RS-115 block units and Miragrid 5XT geogrid

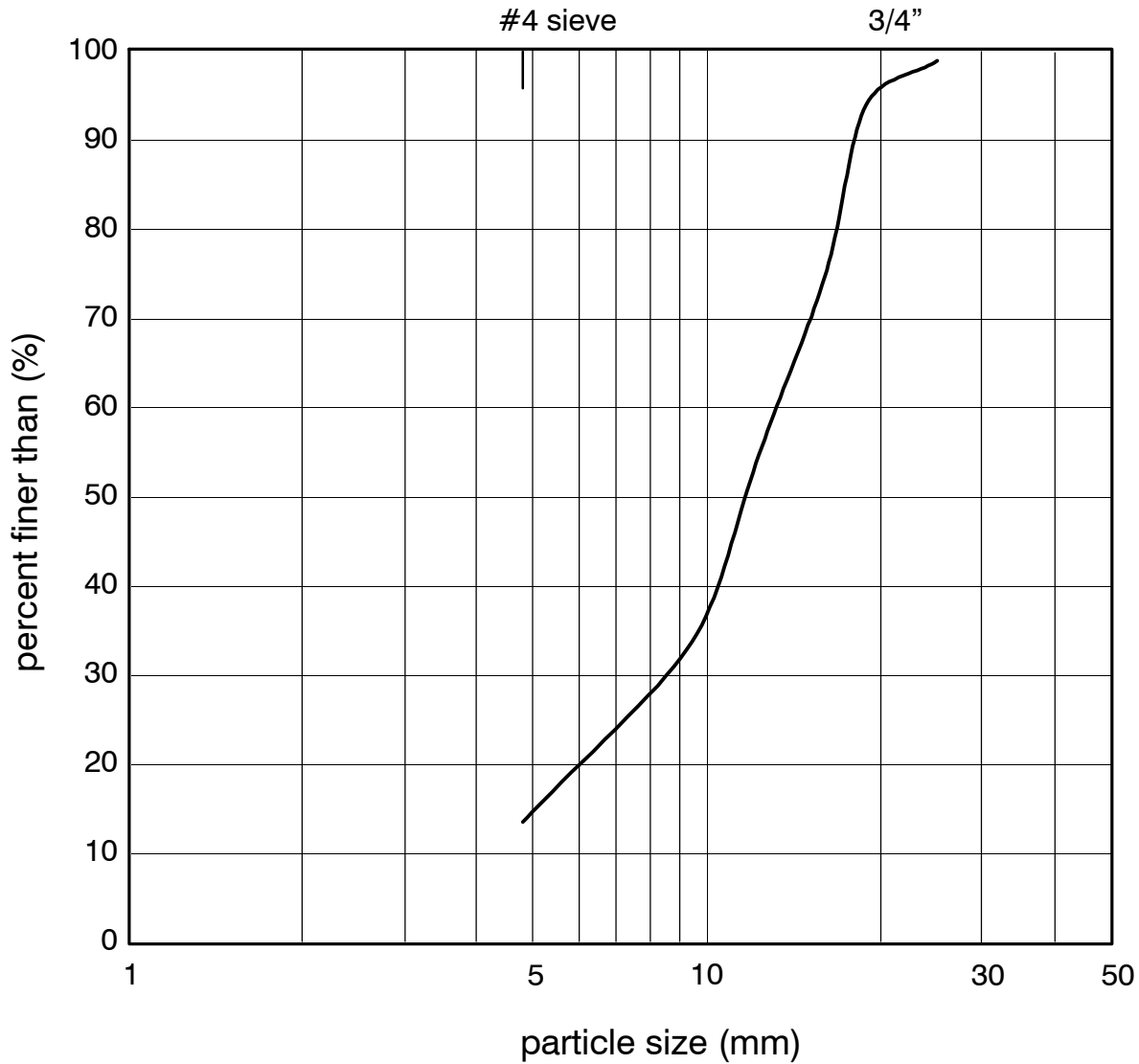

Figure 2: Particle size distribution for 100% crushed granular stone used in RS-115 block tests

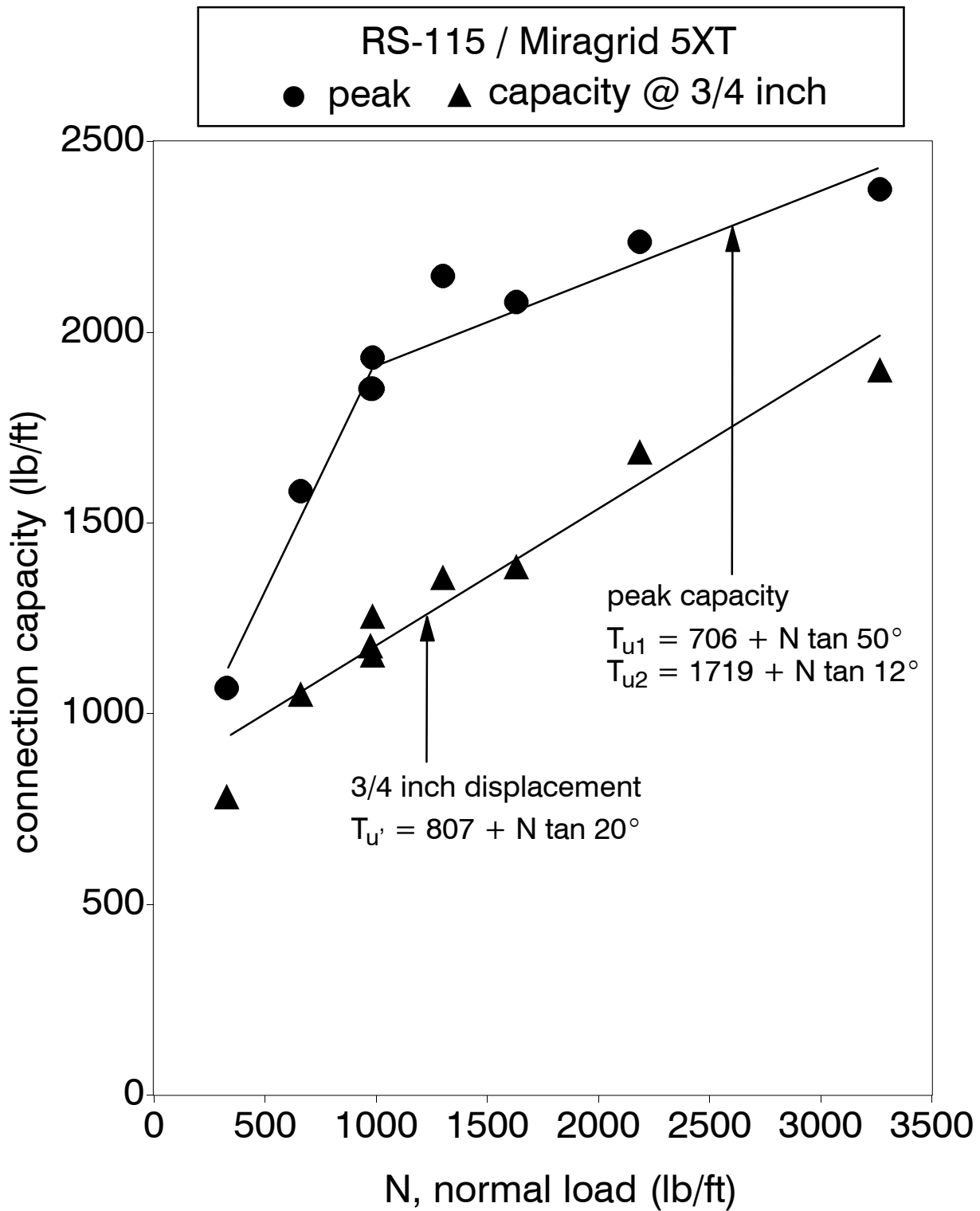

Figure 3: Summary of connection capacities for RS-115 block units and Miragrid 5XT grid

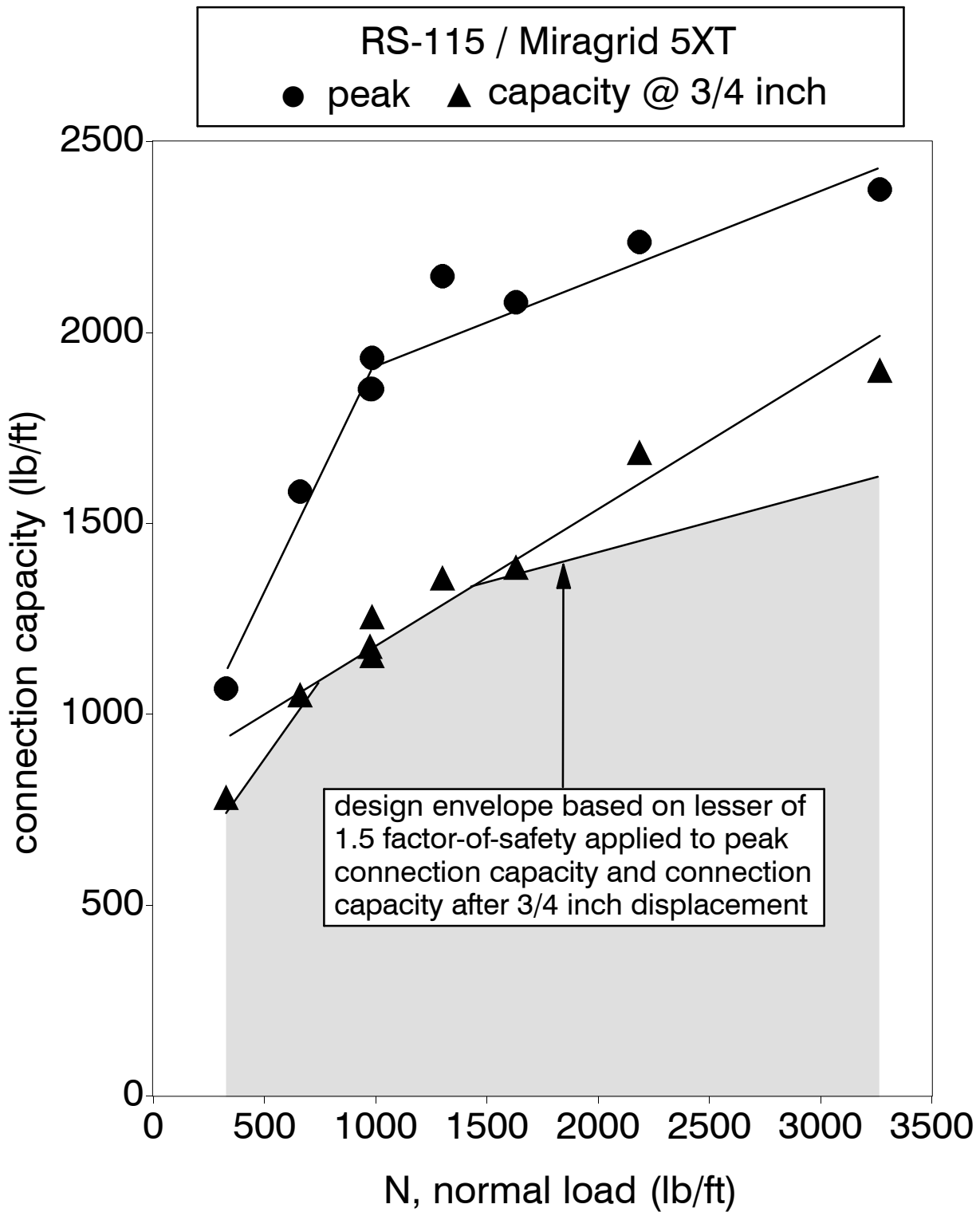

Figure 4: Preliminary design capacity envelope for RS-115 block units / Miragrid 5XT geogrid combination