

Internal Drainage Options

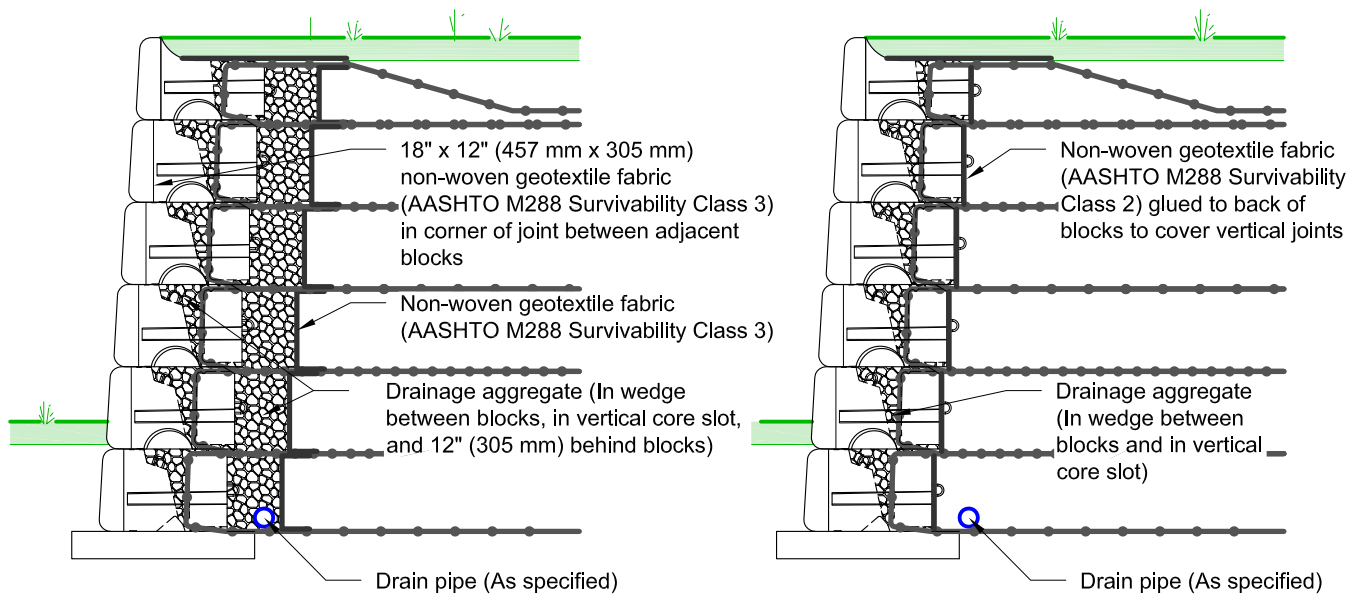

Typical Section - Option 1

Typical Section - Option 2

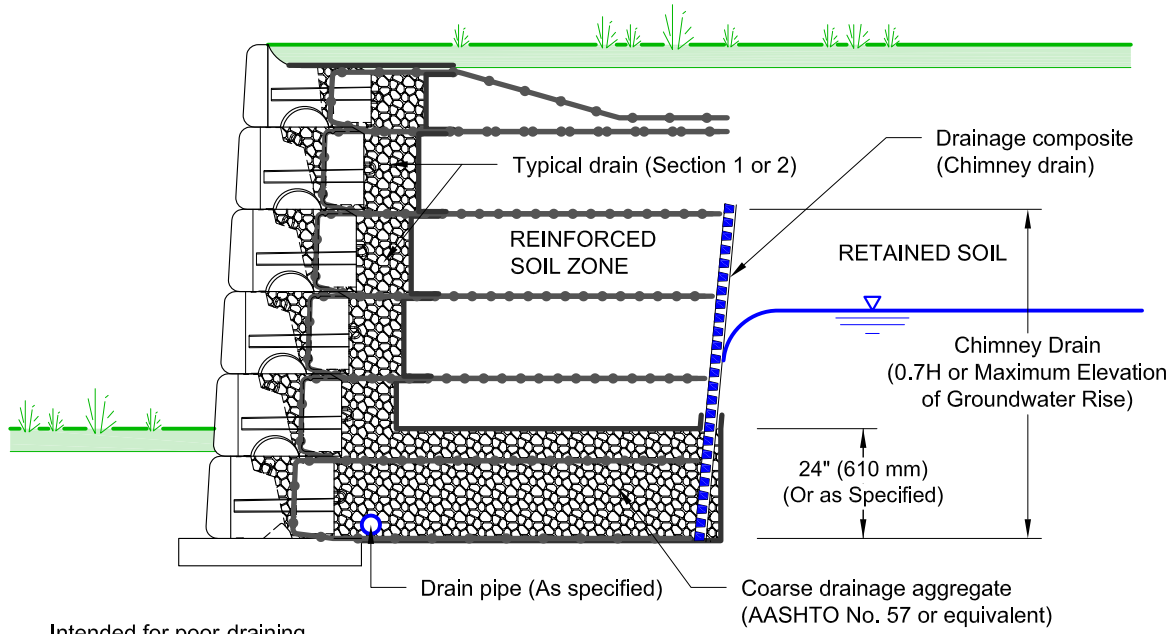

Intended for poor-draining retained soils and/or areas with potential groundwater impact

Blanket and Chimney Drain Section

This drawing is for reference only. Determination of the suitability and/or manner of use of any details contained in this document is the sole responsibility of the design engineer of record. Final project designs, including all construction details, shall be prepared by a licensed professional engineer using the actual conditions of the proposed site.

DRAWN BY:	JRJ	TITLE:	<h2 style="margin: 0;">Wall Drainage Options</h2>	 05481 US 31 SOUTH, CHARLEVOIX, MI 49720 (866) 222-8400 ext 3010 • engineering@red-rock.com www.red-rock.com
APPROVED BY:	JRJ	FILE:		
DATE:	06-22-2015	1 Wall Drainage Options 062215.dwg		
SHEET:	1 of 1			

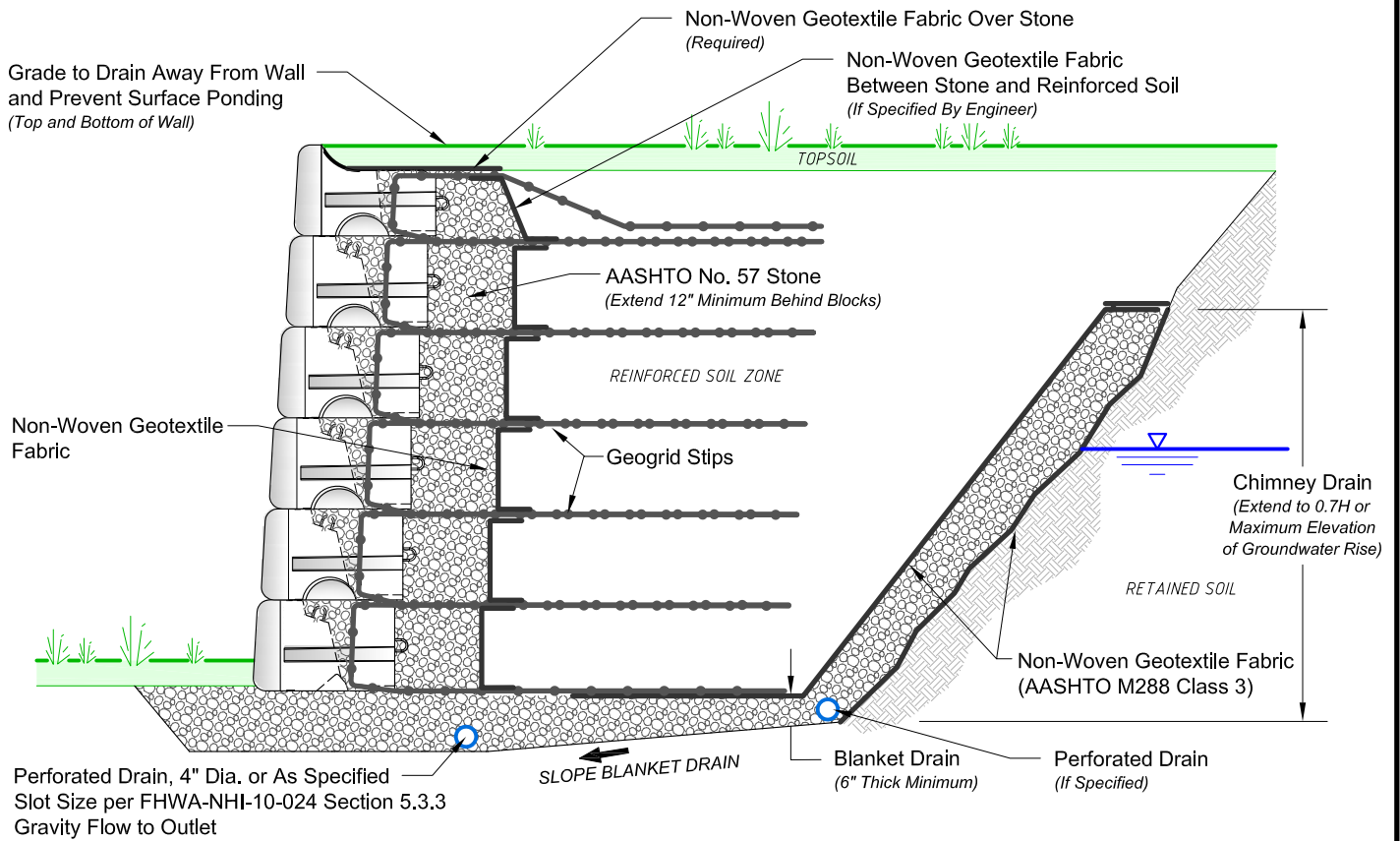

Stone Chimney Drain Section

(POOR-DRAINING RETAINED SOILS AND/OR AREAS WITH POTENTIAL GROUNDWATER IMPACT)
(NO SCALE)

This drawing is for reference only. Determination of the suitability and/or manner of use of any details contained in this document is the sole responsibility of the design engineer of record. Final project designs, including all construction details, shall be prepared by a licensed professional engineer using the actual conditions of the proposed site.

DRAWN BY:	JRJ
APPROVED BY:	JRJ
DATE:	06-22-2015
SHEET:	1 of 1

TITLE:	<h1>Stone Chimney Drain</h1>
FILE:	

REDI-ROCK®
 05481 US 31 SOUTH, CHARLEVOIX, MI 49720
 (866) 222-8400 ext 3010 • engineering@redi-rock.com
www.redi-rock.com

Typical Drainage Detail - Cross Section

Applicable for sites with groundwater well below the leveling pad elevation and well-drained retained soils.

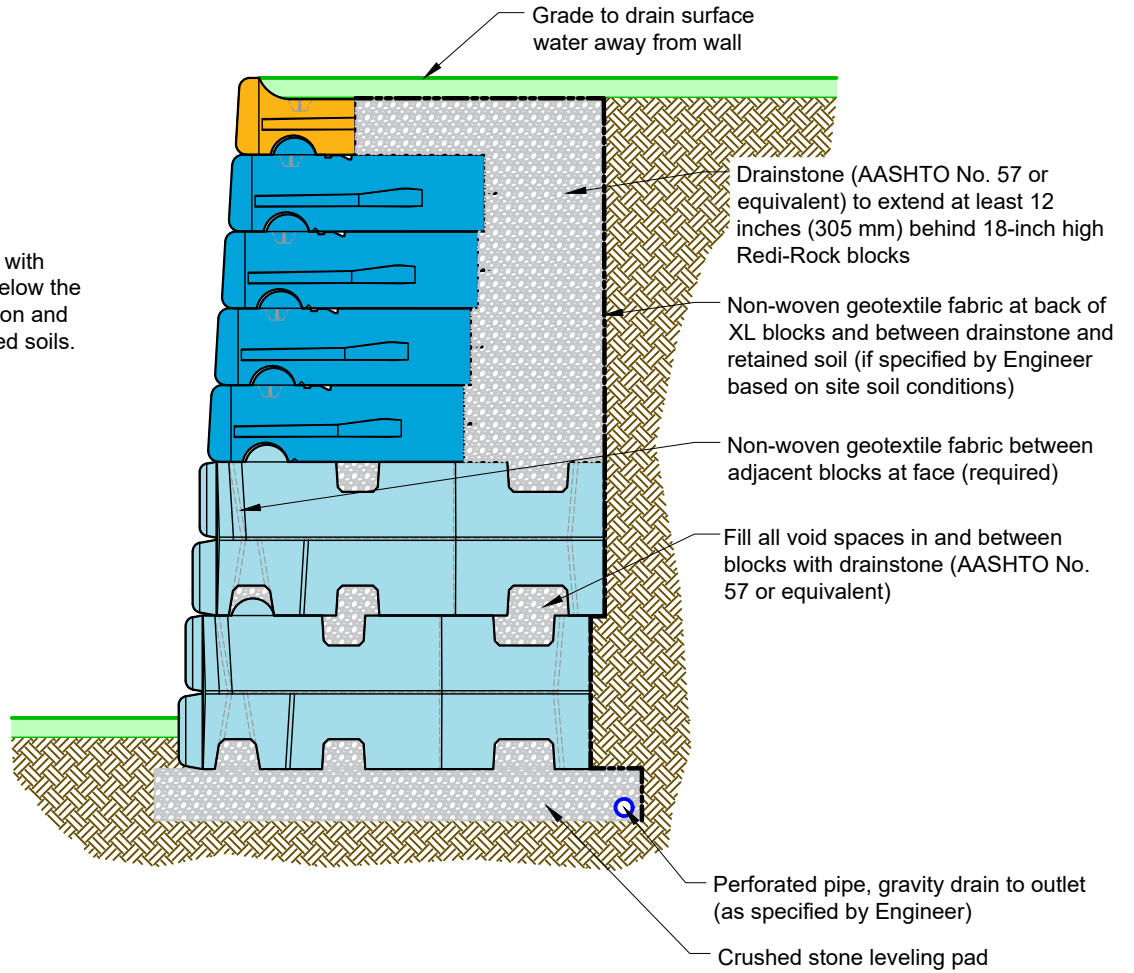

Alternate Detail for Concrete or Impervious Leveling Pad

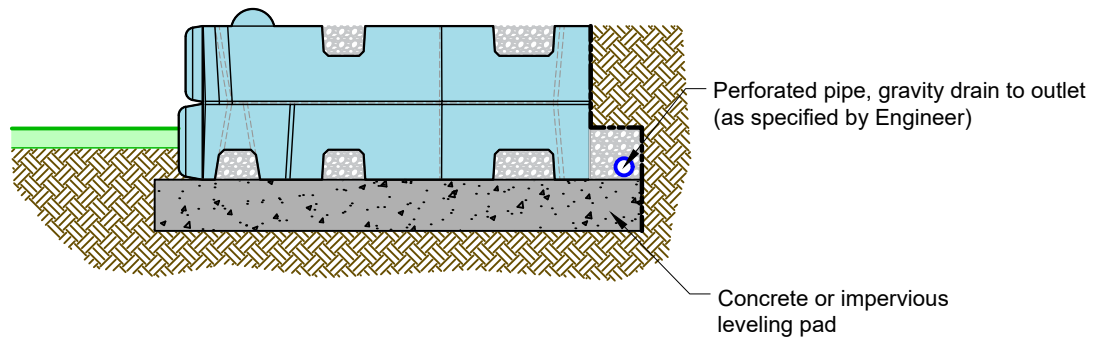

This drawing is for reference only. Determination of the suitability and/or manner of use of any details contained in this document is the sole responsibility of the design engineer of record. Final project designs, including all construction details, shall be prepared by a licensed professional engineer using the actual conditions of the proposed site.

DRAWN BY:	NWL
APPROVED BY:	JRJ
DATE:	22JUN2018
SHEET:	1 of 1

TITLE:	XL Typical Drainage Details
FILE:	XL Typical Drain Section 062218.dwg

REDI-ROCK
 05481 US 31 SOUTH, CHARLEVOIX, MI 49720
 (866) 222-8400 ext 3010 • engineering@redi-rock.com
www.redi-rock.com

Typical Drainage Detail - Isometric View

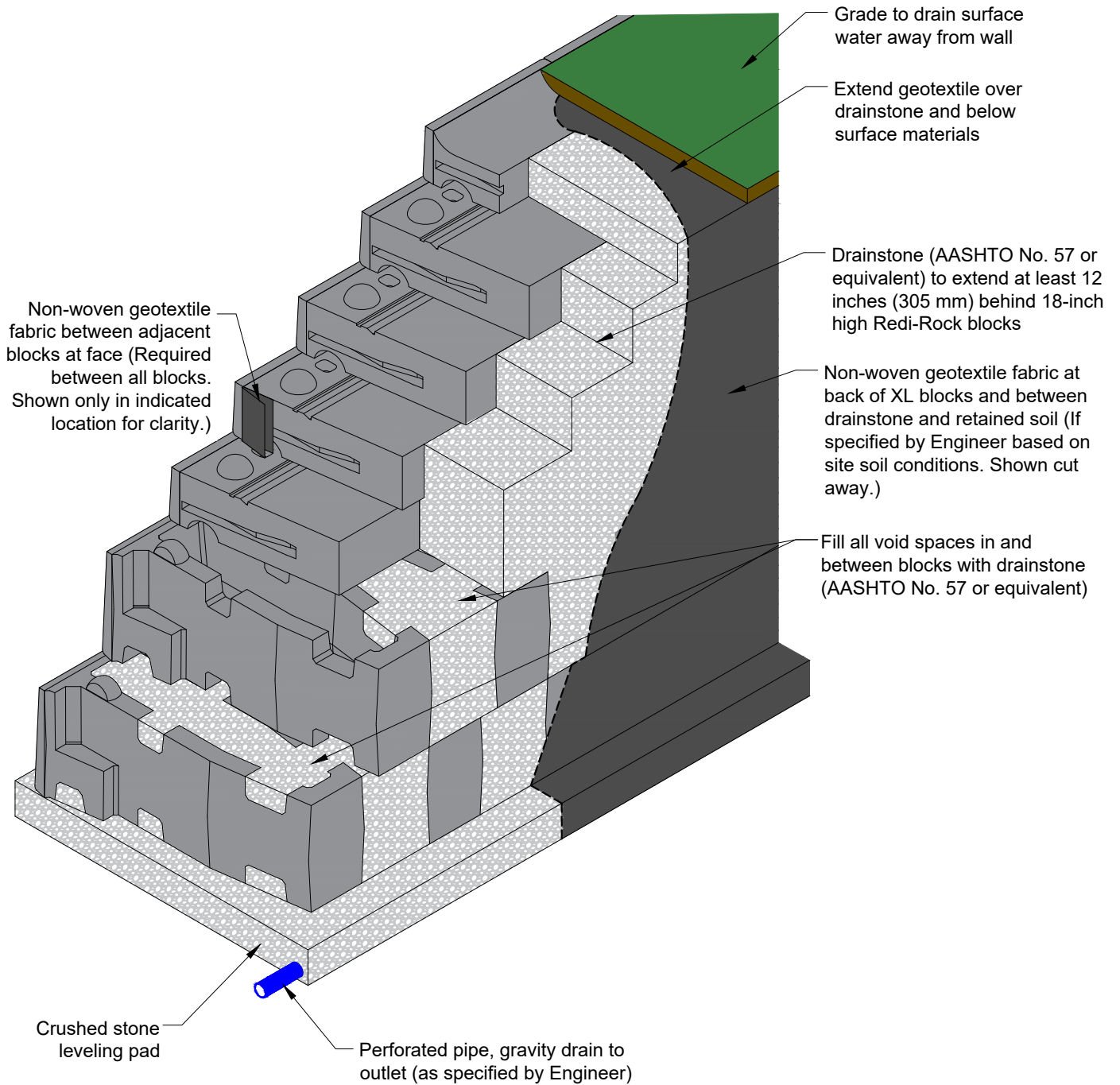

This drawing is for reference only. Determination of the suitability and/or manner of use of any details contained in this document is the sole responsibility of the design engineer of record. Final project designs, including all construction details, shall be prepared by a licensed professional engineer using the actual conditions of the proposed site.

DRAWN BY:	NWL
APPROVED BY:	JRJ
DATE:	22JUN2018
SHEET:	1 of 1

TITLE:	Typical XL Drainage Detail
FILE:	

REDI-ROCK

05481 US 31 SOUTH, CHARLEVOIX, MI 49720
(866) 222-8400 ext 3010 • engineering@redi-rock.com
www.redi-rock.com

LEVELING PAD OPTIONS FOR RETAINING WALL BLOCKS

NO SCALE

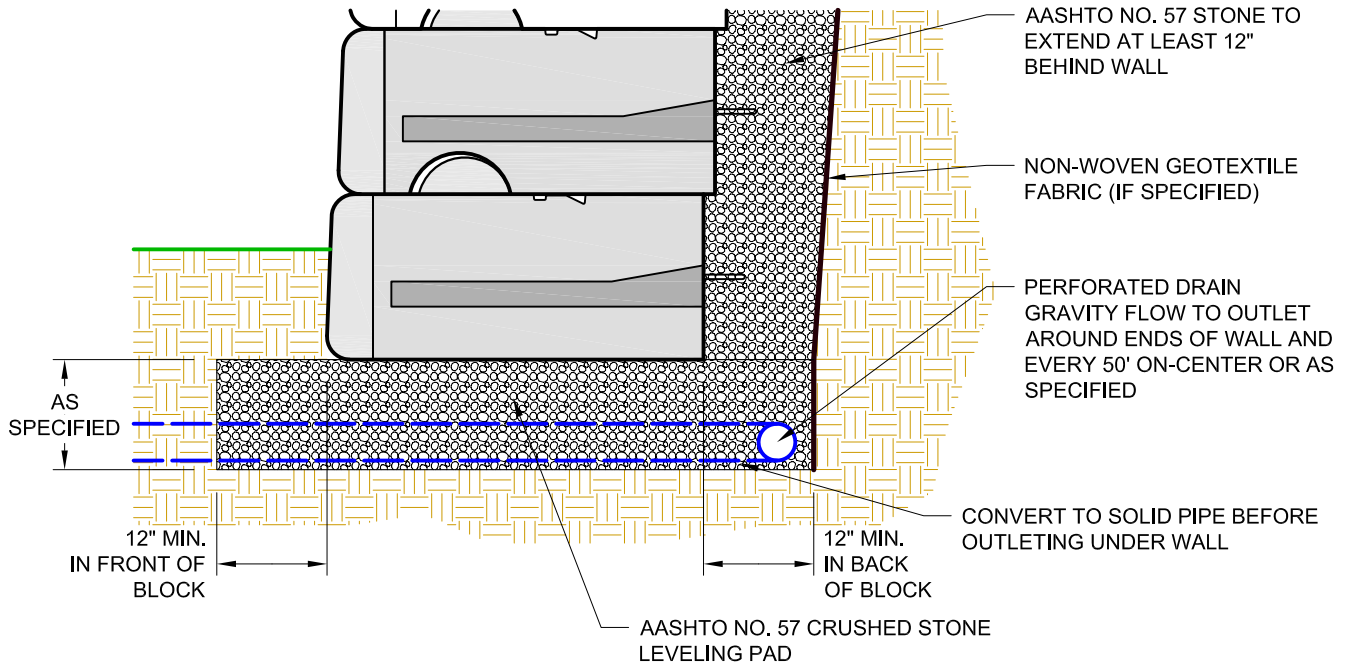

OPEN-GRADED CRUSHED STONE LEVELING PAD

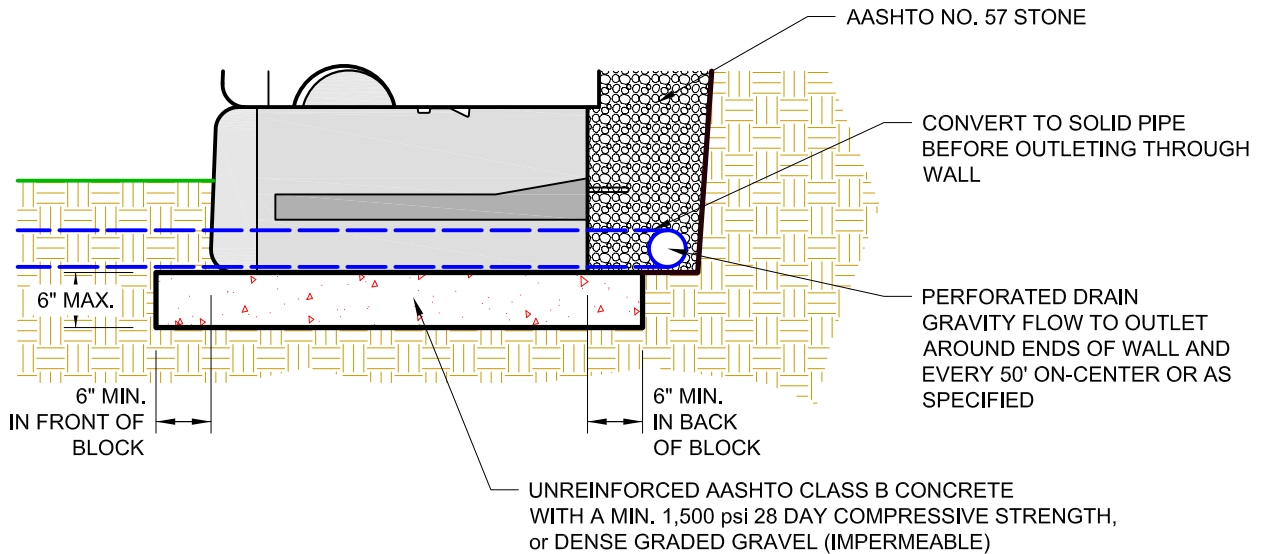

CONCRETE or DENSE GRADED GRAVEL LEVELING PAD

DRAWN BY:	JRJ
APPROVED BY:	JRJ
DATE:	06-22-2015
SHEET:	1 of 1

TITLE:	Leveling Pad Options
FILE:	

REDI-ROCK®
 05481 US 31 SOUTH, CHARLEVOIX, MI 49720
 (866) 222-8400 ext 3010 • engineering@redi-rock.com
www.redi-rock.com

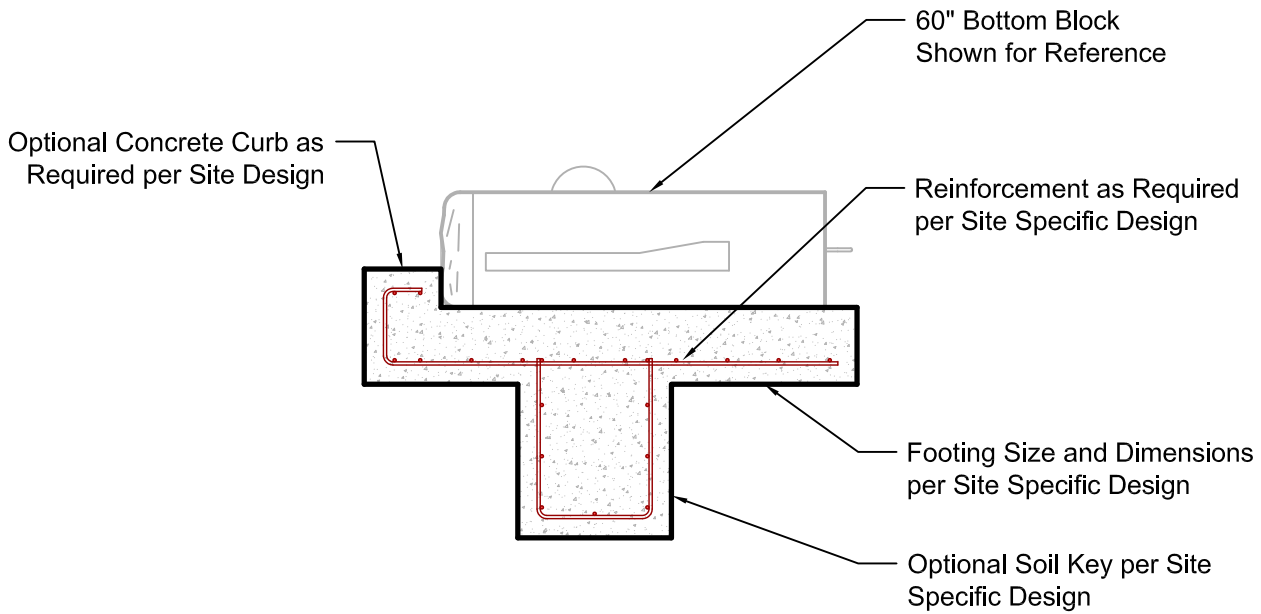

OPTIONAL CONCRETE LEVELING PAD WITH KEYWAY

(NO SCALE)

DRAWN BY:	JRJ
APPROVED BY:	JRJ
DATE:	06-22-2015
SHEET:	1 of 1

TITLE:	Concrete Leveling Pad
FILE:	

REDI-ROCK®
 05481 US 31 SOUTH, CHARLEVOIX, MI 49720
 (866) 222-8400 ext 3010 • engineering@redi-rock.com
www.redi-rock.com

Wall Drain Weep Hole Options

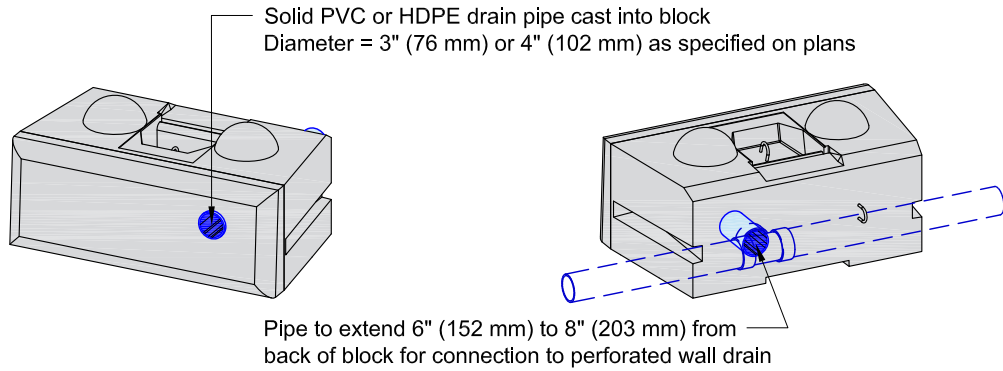

Custom Pipe Cast into Block

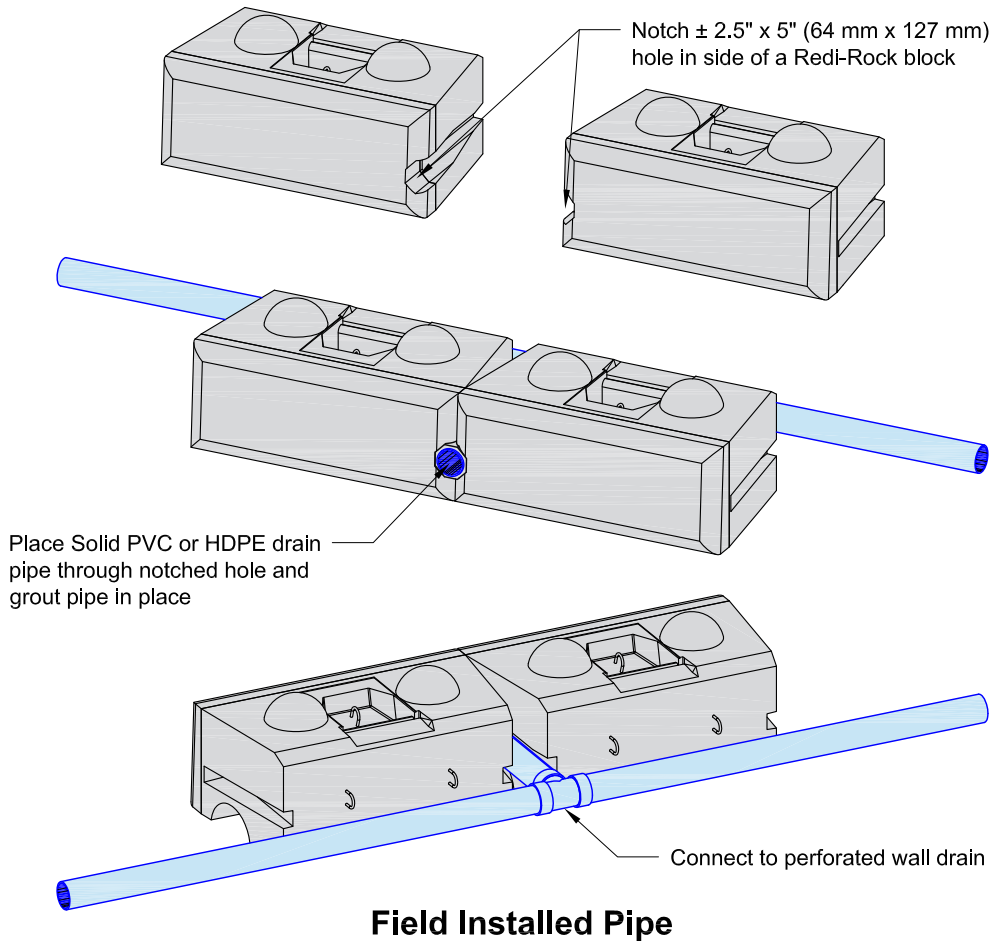

This drawing is for reference only. Determination of the suitability and/or manner of use of any details contained in this document is the sole responsibility of the design engineer of record. Final project designs, including all construction details, shall be prepared by a licensed professional engineer using the actual conditions of the proposed site.

DRAWN BY:	JRJ
APPROVED BY:	JRJ
DATE:	06-22-2015
SHEET:	1 of 1

TITLE:	Drainage Weep Options
FILE:	

REDI-ROCK[®]
 05481 US 31 SOUTH, CHARLEVOIX, MI 49720
 (866) 222-8400 ext 3010 • engineering@redi-rock.com
www.redi-rock.com

STEP FOOTING DETAILS

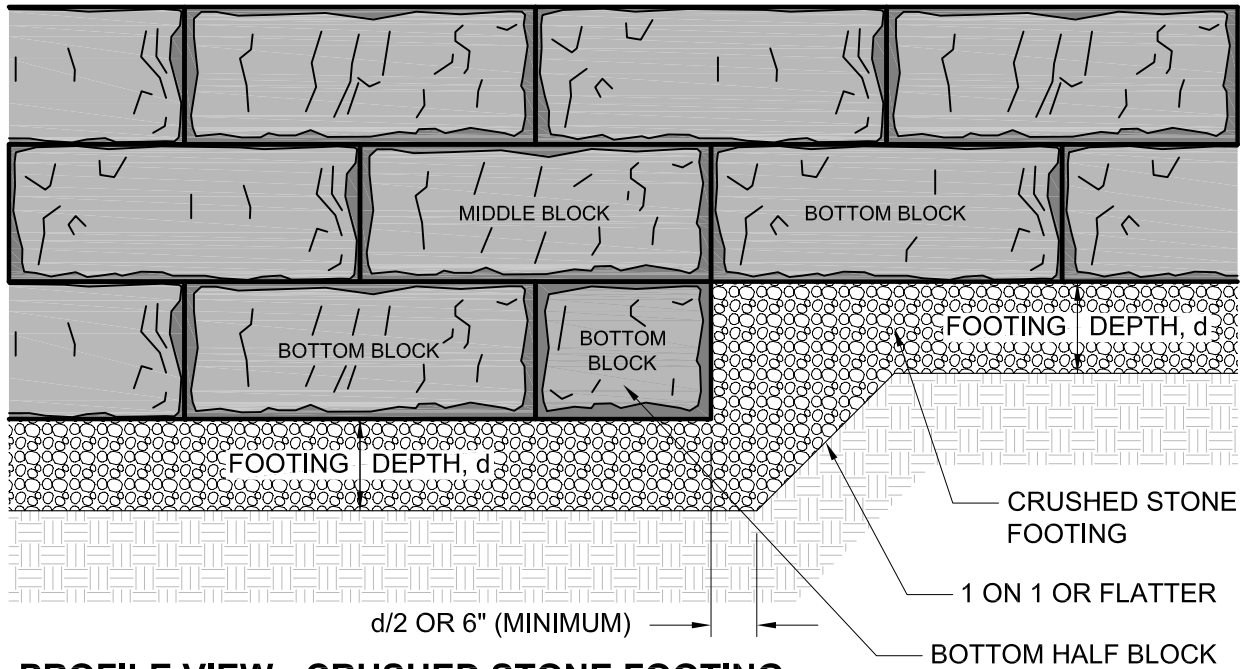

PROFILE VIEW - CRUSHED STONE FOOTING

(No Scale)

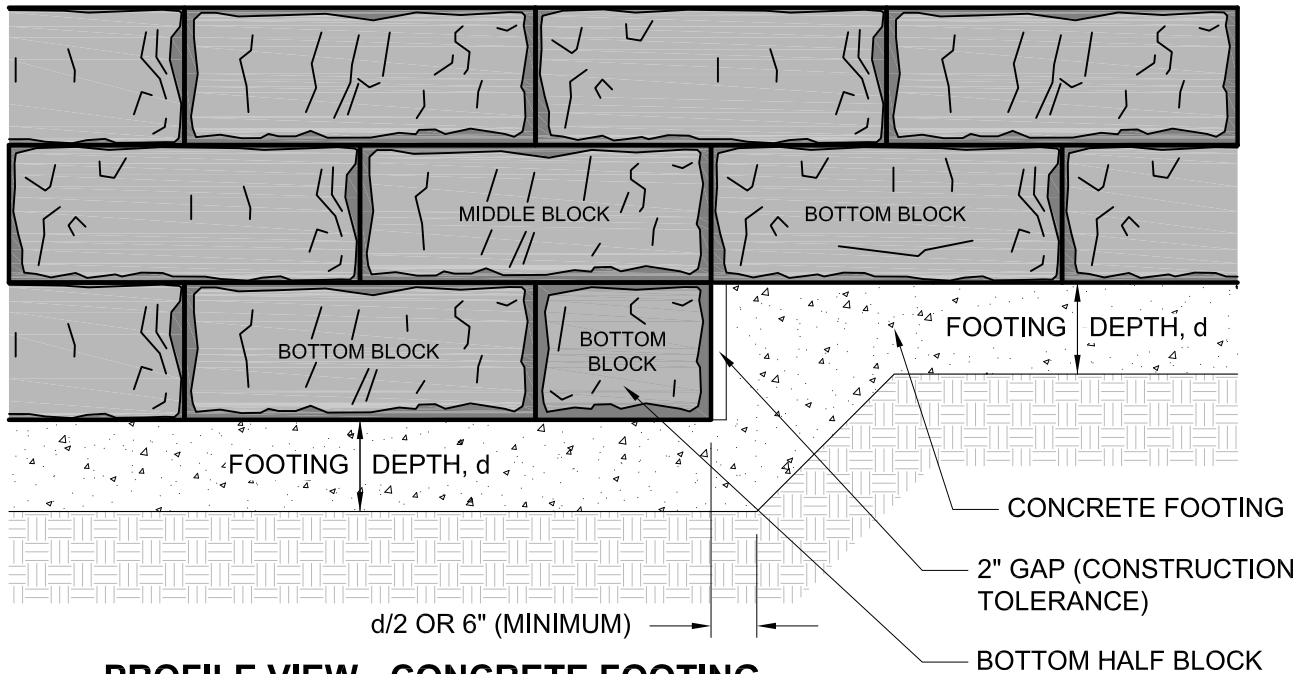

PROFILE VIEW - CONCRETE FOOTING

(No Scale)

DRAWN BY:	JRJ
APPROVED BY:	JRJ
DATE:	06-22-2015
SHEET:	1 of 1

TITLE:	Step Footing Details
FILE:	

REDI-ROCK®

05481 US 31 SOUTH, CHARLEVOIX, MI 49720
 (866) 222-8400 ext 3010 • engineering@redi-rock.com
www.redi-rock.com