

ATTACH FLANGE MOUNTED FENCE POSTS TO CAP UNIT WITH CONCRETE ANCHOR BOLTS (RED HED TRU-BOLT WEDGE ANCHORS OR EQUAL)

SET CAP BLOCK ON TOP F-HC UNIT AND EMBED STEEL REINFORCEMENT IMMEDIATELY AFTER PLACEMENT OF CAST-IN-PLACE CONCRETE

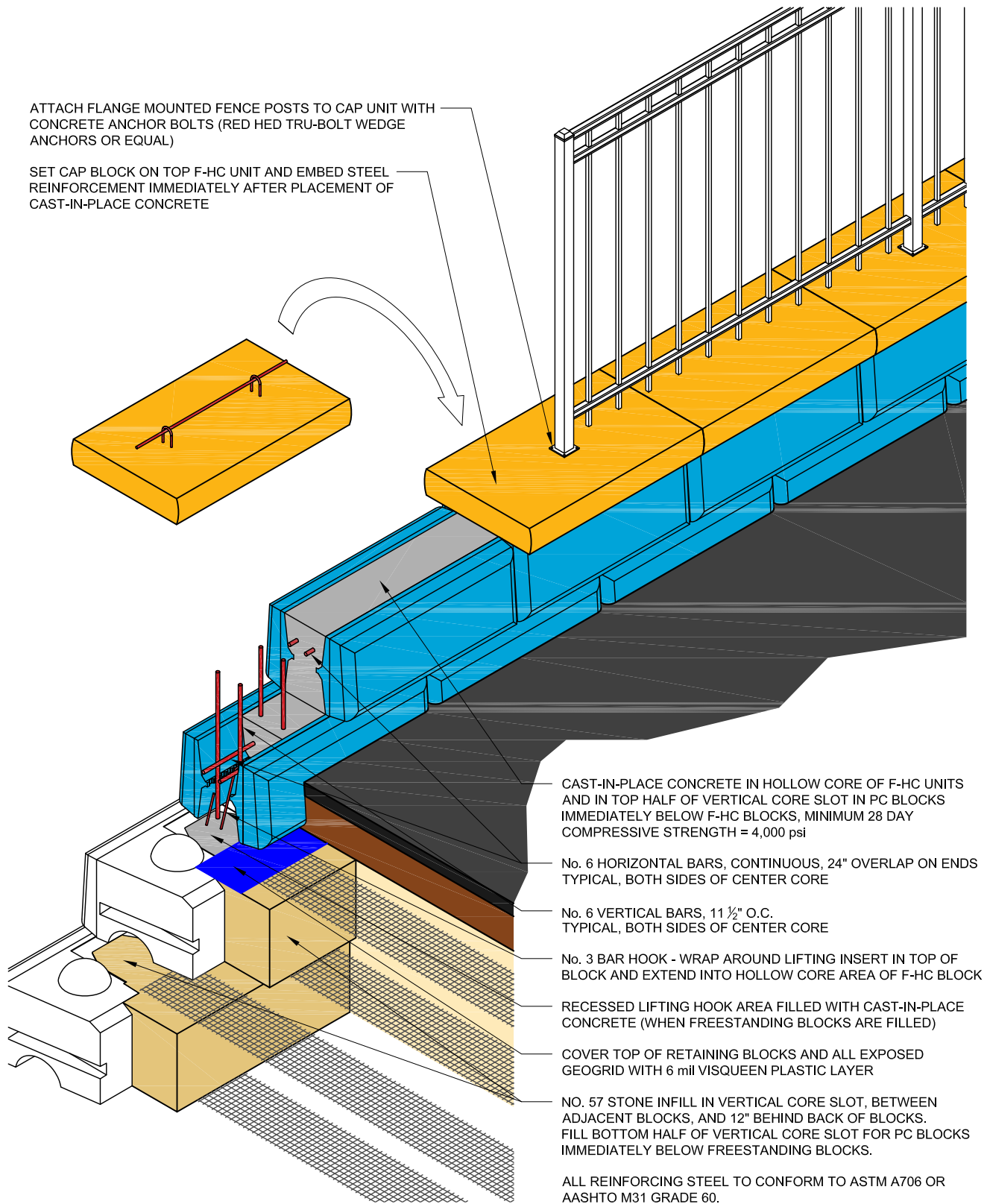

CAST-IN-PLACE CONCRETE IN HOLLOW CORE OF F-HC UNITS AND IN TOP HALF OF VERTICAL CORE SLOT IN PC BLOCKS IMMEDIATELY BELOW F-HC BLOCKS, MINIMUM 28 DAY COMPRESSIVE STRENGTH = 4,000 psi

No. 6 HORIZONTAL BARS, CONTINUOUS, 24" OVERLAP ON ENDS TYPICAL, BOTH SIDES OF CENTER CORE

No. 6 VERTICAL BARS, 11 1/2" O.C. TYPICAL, BOTH SIDES OF CENTER CORE

No. 3 BAR HOOK - WRAP AROUND LIFTING INSERT IN TOP OF BLOCK AND EXTEND INTO HOLLOW CORE AREA OF F-HC BLOCK

RECESSED LIFTING HOOK AREA FILLED WITH CAST-IN-PLACE CONCRETE (WHEN FREESTANDING BLOCKS ARE FILLED)

COVER TOP OF RETAINING BLOCKS AND ALL EXPOSED GEOGRID WITH 6 mil VISQUEEN PLASTIC LAYER

NO. 57 STONE INFILL IN VERTICAL CORE SLOT, BETWEEN ADJACENT BLOCKS, AND 12" BEHIND BACK OF BLOCKS. FILL BOTTOM HALF OF VERTICAL CORE SLOT FOR PC BLOCKS IMMEDIATELY BELOW FREESTANDING BLOCKS.

ALL REINFORCING STEEL TO CONFORM TO ASTM A706 OR AASHTO M31 GRADE 60.

DRAWN BY: J. JOHNSON

APPROVED BY:

DATE: 01/18/17

SHEET: 1 OF 2

TITLE:

**F-HC FREESTANDING BLOCK COPING WITH FENCE ATTACHMENT**

FILE: F-HC Coping with Fence Attachment R-Anchor Option 011817.dwg

**REDI-ROCK**

05481 US 31 SOUTH, CHARLEVOIX, MI 49720  
(866) 222-8400 ext 3010 • engineering@redi-rock.com  
www.redi-rock.com

ALL REINFORCING STEEL TO CONFORM TO ASTM A706 OR AASHTO M31 GRADE 60.

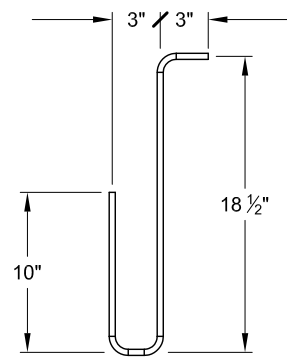

**BEND DETAIL**  
NO. 3 REBAR HOOKS

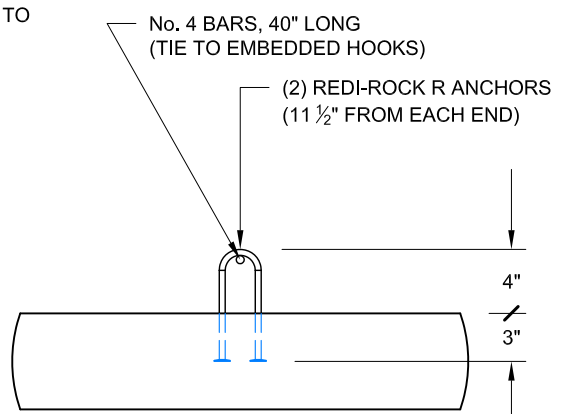

**END VIEW**  
CAP BLOCK CAST WITH R-ANCHORS (SPECIALTY BLOCK)

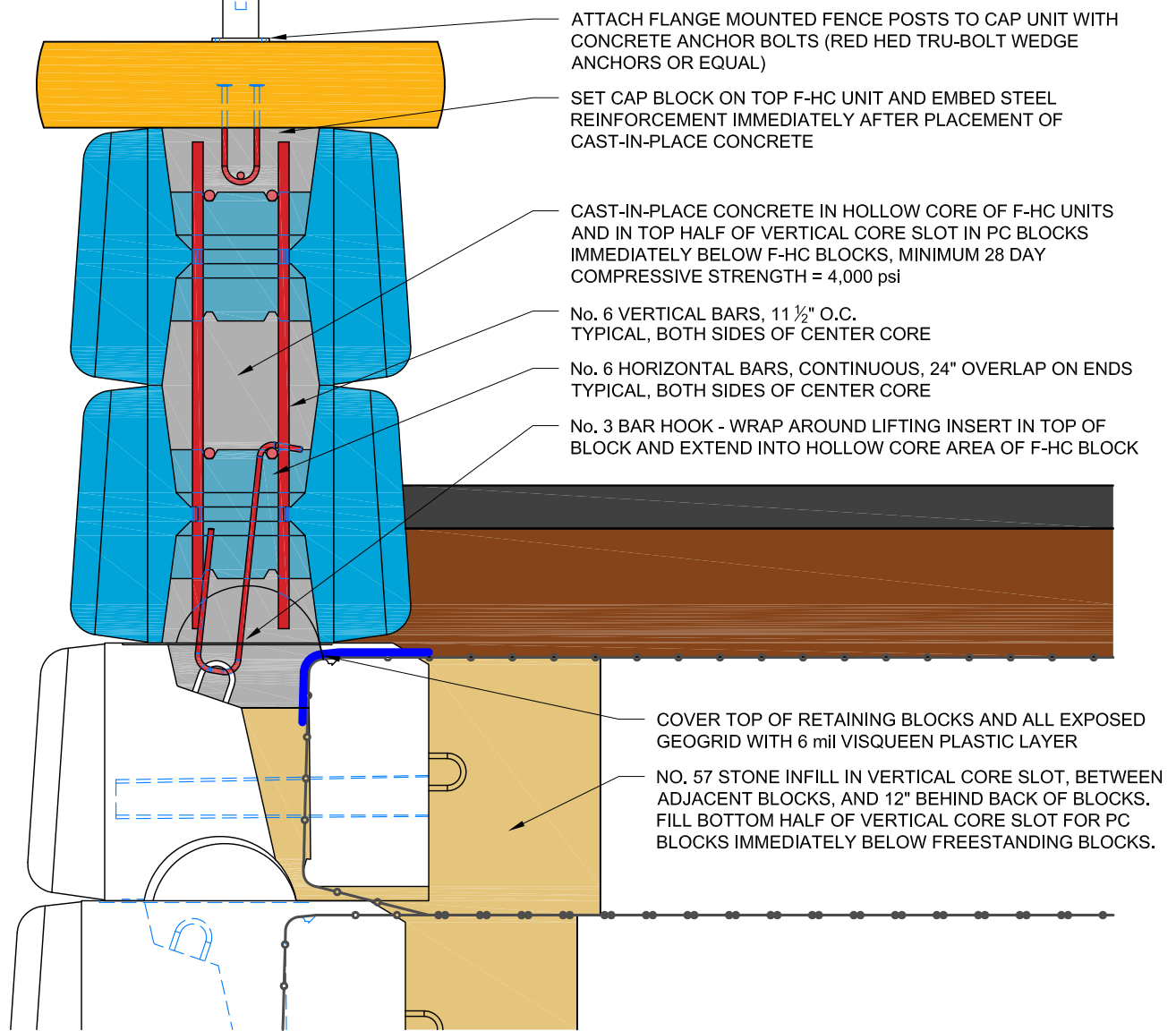

DRAWN BY:	J. JOHNSON
APPROVED BY:	
DATE:	01/18/17
SHEET:	2 OF 2

TITLE:	<b>F-HC FREESTANDING BLOCK COPING WITH FENCE ATTACHMENT</b>
FILE:	F-HC Coping with Fence Attachment R-Anchor Option 011817.dwg

**REDI-ROCK**  
 05481 US 31 SOUTH, CHARLEVOIX, MI 49720  
 (866) 222-8400 ext 3010 • engineering@redi-rock.com  
 www.redi-rock.com