

BLOCK SETBACK OPTIONS

NOT TO SCALE

FIVE DEGREE (5°) SETBACK

(STANDARD)

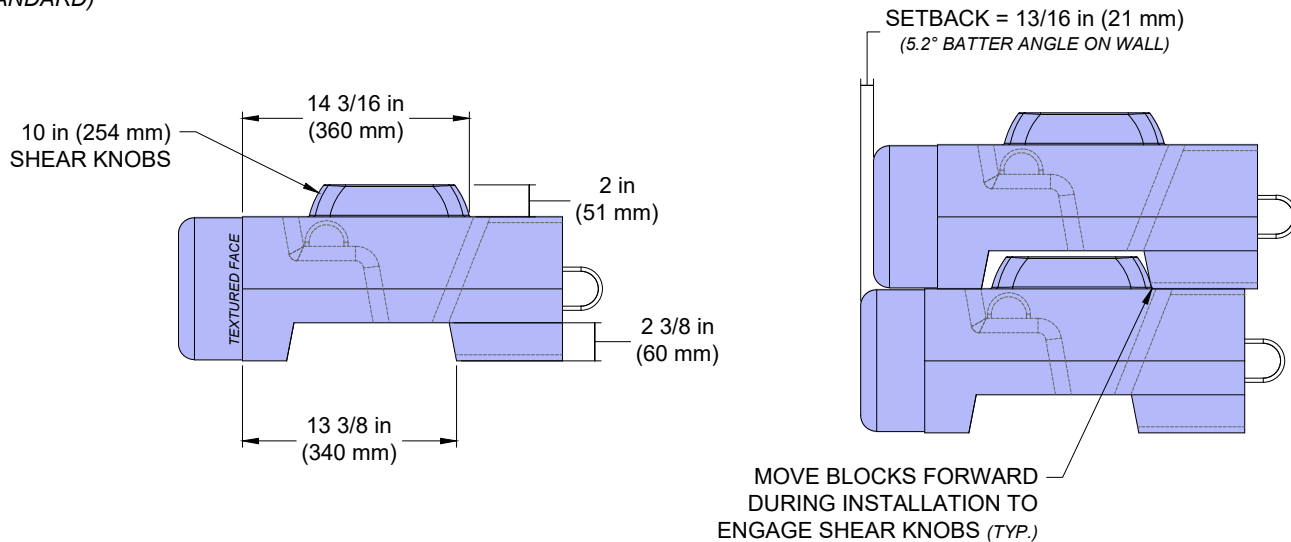

ZERO DEGREE (0°) SETBACK

(SPECIALTY)

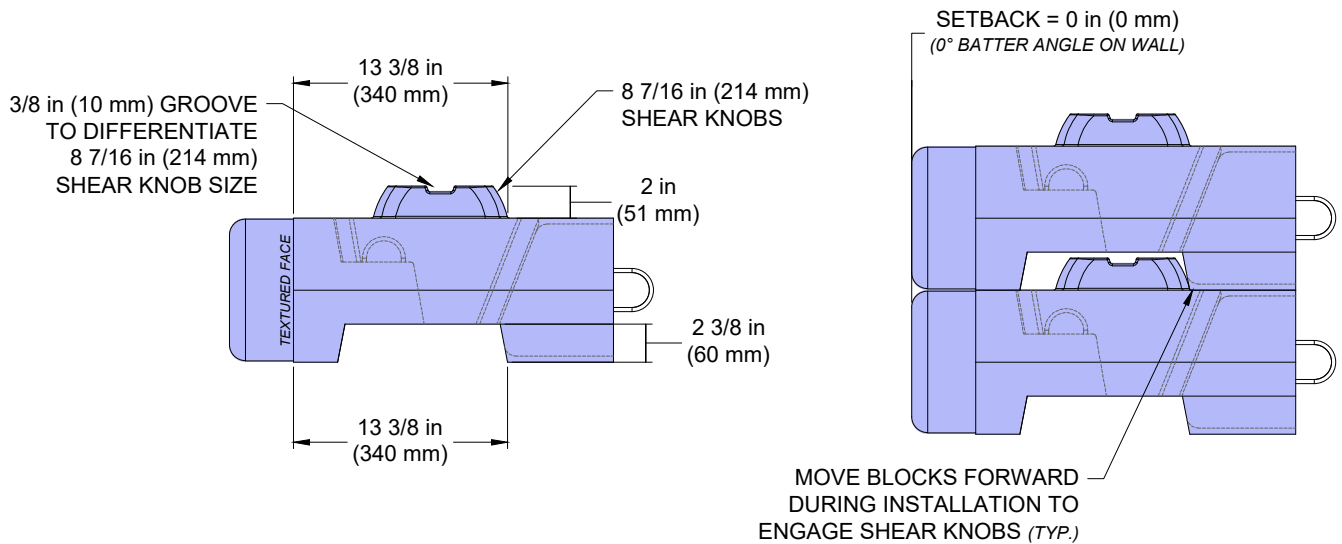

The block-to-block setback available with Novum Wall is controlled by the size and location of the shear knobs cast into the block. The standard configuration is a 10 in (254 mm) by 5 in (127 mm) knob in a 13/16 in (20 mm) setback per position, resulting in a 5.2° wall batter. Novum Wall blocks also have a specialty option available with a 8 7/16 in (214 mm) by 5 in (127 mm) knob in a 0 in (0 mm) setback position, resulting in a 0° wall batter. 8 7/16 in (214 mm) shear knobs include a 3/8 in (222 mm) groove on top of the shear knob to differentiate them from the 10 in (254 mm) shear knobs.

Due to variability in the Novum Wall block face texture, block setback is most accurately field measured from the block form line.

This drawing is for reference only. Determination of the suitability and/or manner of use of any details contained in this document is the sole responsibility of the design engineer of record. Final project designs, including all construction details, internal and external stability, and drainage, shall be prepared by a licensed professional engineer using the actual conditions of the proposed site.

DRAWN BY:	TDG
APPROVED BY:	LBH
DATE:	29-MAY-2024
SHEET:	1 of 1

TITLE:	BLOCK SETBACK OPTIONS	
FILE:		Block_Setback_Options.dwg

NOVUM WALL™

3890 CHARLEVOIX AVE, PETOSKEY, MI 49720
(866) 222-8400 ext 33010 • engineering@redi-rock.com • www.novumwall.com