

MANUFACTURER: _____

SALES ORDER: _____

PHONE #: _____

P.O. NO.: _____

EMAIL: _____

DATE: _____

CUSTOMER: _____ JOB/LOCATION NAME: _____

DESIGN BY OTHERS

BASE DIAMETER: _____

BASE LENGTH: _____

HORZ. BARS (SIZE & SPACING): _____

VERT. BARS (QTY. & LENGTH): _____

BOLT CIRCLE: _____

BOLT PROJECTION: _____

SIZE OF BOLTS: _____

WEIGHT: _____

CONDUIT INFORMATION		
SIZE	ANGLE	DEPTH (FROM TOP OF BASE)

NOTE:
1.) DESIGN BY OTHERS
2.) GRADE 60 REBAR
3.) F'c = 5000 PSI

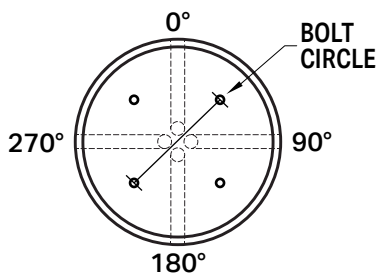

Reference only - see table for actual location

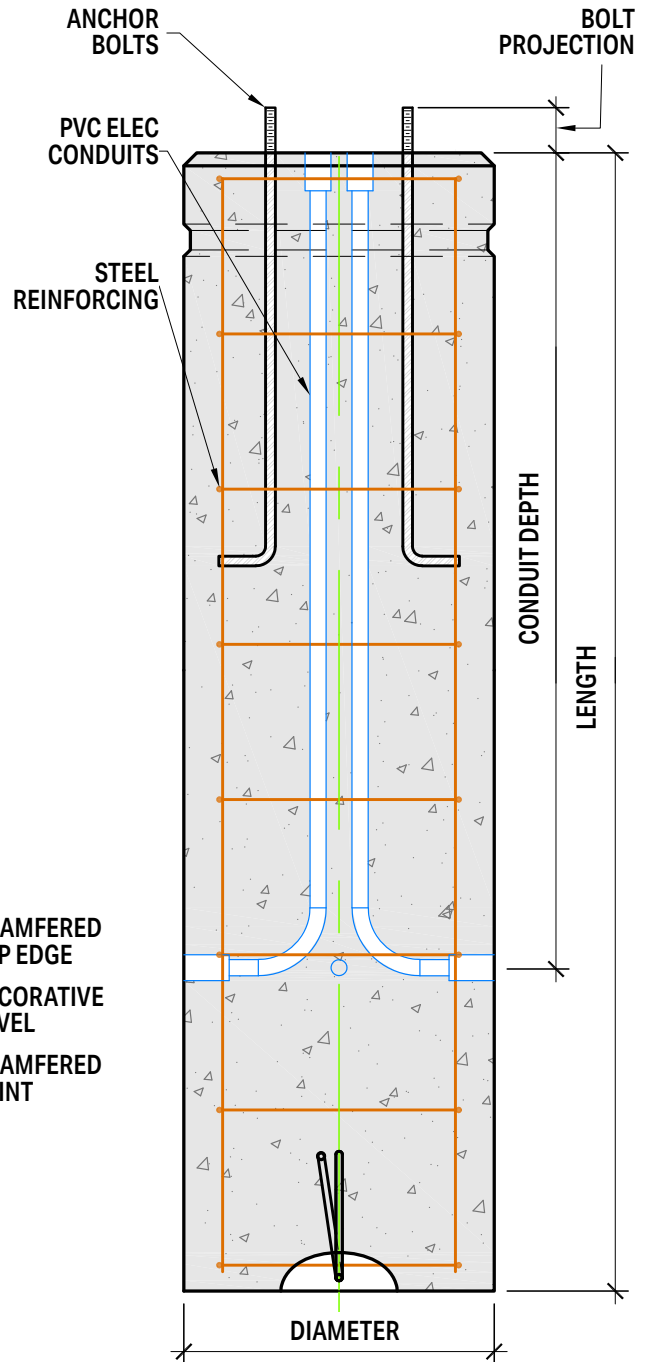
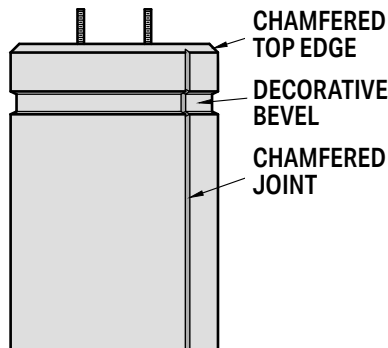

CUSTOMER APPROVAL

SIGNATURE: _____ PRINT NAME: _____

This drawing and all information on it supersedes any other information received or provided by customer and/or supplier of light pole.